

# NOVENARY

Catalog 24/25





# OUR PRODUCT CATEGORIES



**Business Type**



**Cooking Appliances**



**Ventilation**



**Pizza & Grill**



**Stainless Steel Furniture**



**Refrigeration**



**Combi Steamer**



**Kitchen Appliances**



**Heat retention**



**Rinsing & Cleaning**



**Retail Refrigeration**



**Café & Ice Cream**



**Kitchenware**



**Table Setting**

Alongside our excellent advice and premium quality, what sets us apart is our variety of catering equipment. Whatever you require, we can deliver at the best price!

So you have the opportunity to buy everything from one supplier. This means better conditions, quicker delivery and perfectly adapted products to meet your needs.

# FOOD PROCESSING EQUIPMENT



3

- Food slicer
- Vegetable slicer
- Vegetable cutter
- Potato peeler
- Potato spiral cutter
- Manual potato cutter
- Manual cutting machine
- Praline cutter
- Tomato slicer
- Kebab slicer
- Horizontal cutter
- Curry sausage slicer
- Electric meat tenderiser
- Mincing machine
- Meat mixer
- Manual meat tenderizer
- Sausage stuffer
- Bone saw
- Cake smoothing machine
- Hamburger machine
- Mixer
- Dough kneading machine
- Bakery dough sheeter
- Horizontal cutter stand
- Hand blender
- Spindle mixer
- Churro machine
- Manual donut tool
- Hopper
- Filling machine
- Electric oil press
- Juice extractor
- Food mixer
- Orange squeezer
- Vacuum machine
- Mobile glass washer
- Dish washer
- Honey extractor
- Sesame peanut butter machine
- Poultry plucker
- Poultry plucker and scalding
- Scalding kettle poultry
- Hand dryer
- Shoe polisher
- Can opener
- Juice extractor manually
- Knife sharpener
- Manual stainless steel sausage clipper
- Table ice crusher
- Food trailer



# FOOD PROCESSING

## FOOD SLICER



- Pure copper motor
- Adjustable thickness
- Have a sharpening stone.

Model	Product Dim (W/D/H mm)	Voltage /Frequency (V/Hz)	Power (W)	Motor Speed (r/ min)	Slice Thickness (mm)	Maximum slice width (mm)	40 HQ Container loading
AMH220	425x388x329	220-240/50	120	1400	0.2-12	160	612
AMH250A	482x414x364	220-240/50	150	1400	0.2-12	180	400
AMH275A	543x462x430	220-240/50	250	1400	0.2-15	180	288
AMH300A	576x465x430	220-240/50	250	1400	0.2-15	200	288
AMH250L	482x392x375	220-240/50	150	1400	0.2-12	180	400
AMH275L	547x490x422	220-240/50	250	1400	0.2-15	180	288
AMH300L	577x491x427	220-240/50	250	1400	0.2-15	200	288
AMH350	763x629x546	220-240/50	400	1400	0.2-30	320	126
AAMH300	592x580x696	220-240/50,60	550	1400	0-15	200	162
AAMH320	747x582x764	220-240/50,60	370*2	1400	0.2-18	230	90
AAMH250	514x484x521	220-240/50,60	370	1400	0-16	185	252
AAMH320N	661x572x660	220-240/50,60	750	1400	0-16	220	153
AAMH360	1072x749x1494	220-240/50,60	750*2	1400	0-25	350	28
AMVH350	767x666x609	220-240/50	400	1400	0-30	240	90
AMH220N	416x362x339	220-240/50	120	1400	0-12	160	756

## FOOD SLICER

- Pure copper motor
- Adjustable thickness
- Have a sharpening stone.



AMH220R  
AMH250R  
AMH300R



AMSH300



UGH300

- Adjustable thickness according to requirements
- With sharpening device
- Very simple mechanical operation
- Strong and resistant

Model	Product Dim (W/D/H mm)	Voltage /Frequency(V/Hz)	Power(W)	Motor Speed(r/min)	Slice thickness (mm)	Maximum slice width (mm)	40 HQ Container Loading
AMH220R	479x404x350	220-240/50	120	1400	0-12	160	400
AMH250R	482x414x364	220-240/50	150	1400	0-12	180	400
AMH300R	576x465x430	220-240/50	250	1400	0-15	200	288
AMSH300	716x557x563	/	/	/	0-2	250	140
UGH300	480x480x745	/	/	/	/	/	200

## VEGETABLE SLICER



GEH  
GEH5



GEH5R



GSH300

- Simplifies the preparation of vegetables in the kitchen
- Efficient cutting of different types of vegetables
- Ideal solution for professional use
- Silent operation
- High quality
- Space saving design
- Easy to clean

- A cutting bowl and a vegetable cutter attachment works on the same plastic motor base
- Polycarbonate lid designed to allow the addition of liquid or ingredients during processing
- Single speed 1500 rpm for two attachments
- Compact design and medium duty can meet most of daily kitchen use
- Interlocked apparatus included for safety use
- Direct drive motor
- Detachable blades and discs



GEA4



EBA5



GSA5

- Versatile and efficient: you can quickly process food to achieve different results with an excellent finish
- Utmost hygiene: the components are manufactured from materials suitable for food handling and can be easily removed for fast cleaning
- Ventilated motor: powerful and low-noise can perform all processes effortlessly
- Controls with low-voltage (24V) switch
- Discs and blades for all kinds of processing

Model	Product Dim(W/D/H mm)	Voltage /Frequency (V/Hz)	Power (W)	Motor Speed(r/min)	40 HQ Container loading
GEH	246x614x506	220-240/50,60	550	1400	712
GEH5	246x614x506	220-240/50,60	550	1400	712
GEH5R	246x614x506	220-240/50,60	550	1400	712
GSH300	268x575x528	220-240/50,60	550	1400	760
GEA4	430x285x691	220-240/50,60	735	1500	441
EBA5	289x244x260	-	-	-	2688
GSA5	570x240x540	220-240/50,60	750	1500	378

# FOOD PROCESSING

## VEGETABLE CUTTER



- Desk model
- Device can be clamped to any table top by means of a screw
- connection Disc thickness: 0,3 - 8 mm
- Ideal solution for professional use
- Body made of premium stainless steel
- Efficient work possible
- Easy to clean

Model	Product Dim (W/D/H mm)	NW/GW(kg)	40 HQ Container loading
MGHH	320x280x410	3.8/4.4	900



- Stainless steel body and bucket
- With S-shaped blade, 10 second high-speed shredding
- Stepless speed regulation
- With non-slip feet



Model	Product Dim (W/D/H mm)	Voltage/ Frequency (V/Hz)	Power(W)	Motor Speed (r/min)	Maximum working capacity(L)	40 HQ Container loading
CUH6N	524x316x394	220-240/50,60	1800	986-2470	6	600
CUH9N	523x316x444	220-240/50,60	1800	986-2470	9	600
CUH12N	525x316x489	220-240/50,60	2000	1100-2800	12	480

## POTATO PEELER

- Suitable for potatoes
- Containers with grip handles
- Safety micro switch on door and lid
- Interior walls with friction lining
- Emptying flap made of polished aluminium
- Non-slip feet made from stainless steel
- Simple operation
- Easy to clean
- Housing and containers made from stainless steel
- Transparent plastic lid



Model	Product Dim (W/D/H mm)	Voltage /Frequency (V/Hz)	Power (W)	Motor Speed (r/min)	Capacity(kg/h)	40 HQ Container loading
KSH300	413x586x1090	220-240/50	750	960	165	154
KSH400	465x616x1121	220-240/50	950	960	225	124

## POTATO SPIRAL CUTTER

- Simple design for easy operation
- All stainless steel construction potato slicer which is designed for slicing twisted potato chips.



Model	Product Dim(W/D/H mm)	40 HQ Container loading
MKSK01	260x120x140	6500

## MANUAL POTATO CUTTER



KSMNP

- Quick and easy production of wavy cut fries
- Base plate with suction pads
- Made of high quality stainless steel
- Easy to clean
- Easy to use

Model	Product Dim (W/D/H mm)	NW/GW(kg)	40 HQ Container loading
KSMNP	490X160X80	3/3.2	2640

## MANUAL CUTTING MACHINE

- Suitable for coarse dicing of vegetables and fruit
- Ideal solution for professional use
- Efficient work possible
- Made of high quality stainless steel
- Easy to clean



SCMMNP



GSMHH6  
GSMHH9  
GSMHH12

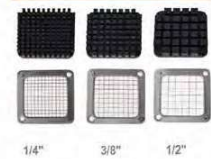
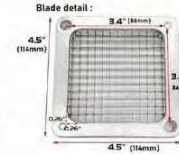

Model	Product Dim (W/D/H mm)	Cube Thickness(mm)	NW/GW(kg)	40 HQ Container loading
SCMMNP	508x381x610	25	7.3/7.5	460
GSMHH6 GSMHH9 GSMHH12	205x205x480	6.35 9.53 12.7	2.85/3.2	1400

## PRALINE CUTTER



- Praline cutter with two frames
- Perfect for pastry shops
- Excellently suited for use in professional kitchens
- Made of high quality stainless steel
- For cutting chocolates
- Easy to clean

Model	Product Dim (W/D/H mm)	Frame(mm)	Wire Spacing(mm)	NW/GW(kg)	40 HQ Container loading
PSNP20	263X670X550	200x210	28 & 14	7.52/8	1650
PSNP23	518 x 474 x 568	234 x 220	21 & 28	8.5/9	1650
PSNP28	338x537x695	280 x 275	20 & 28	24.5/25.5	900
PSNP30	629X553X695	300 x 365	23 & 89	14.5/15.5	1356
PSNP36	629X613X694	360 x 360	15, 22.5 & 30	27.5/34.5	594

# FOOD PROCESSING

## TOMATO SLICER

- Made of high quality stainless steel
- Ergonomic hard plastic handle
- Rubber feet for secure the stability
- Easy to clean



TSH400  
TSH550



TSH100

- Body made by stainless steel
- Simple operation
- With non-slip feet

Model	Product Dim(W/D/H mm)	Slice thickness (mm)	40 HQ Container loading
TSH400	430x200x195	4	2200
TSH550	430x200x195	5.5	2200
TSH100	355X260X485	/	2520

## KEBAB SLICER

- Perfect for doners, gyros, chicken doners and shoarma
- Full stainless steel blade cover
- On/off switch in the trigger position and an abrasion-resistant surface
- Lightweight plastic anti-slip body
- Adjustment ring and screw for desired thickness
- Equipped with blade protector and overload protection button



KS100C



KS100E



DSA80S

- Full stainless steel blade cover
- Adjustment ring and screw for desired thickness
- Metal anti-slip body, ergonomic design, safe and easy handling
- The front part is easily detachable for cleaning
- Wear-resistant switch
- An adapter and a slicer stand included

Model	Product Dim (W/D/H mm)	Voltage/ Frequency (V/Hz)	Power(W)	Cutting Depth(mm)	Capacity(kg/day)	Blade Dia. (mm)	40 HQ Container loading
KS100C	170x170x150	Li-ion Battery 12	80	0-8	60	Φ100	8646
KS100E	180x180x180	220-240/50	80	0-8	60	Φ100	5418
DSA80S	283x120x115	220-240/50	80	0-6	80	Φ80	5292

## HORIZONTAL CUTTER



HCH8N  
HCH14N



- With copper motor
- With waterproof switch
- With non-slip feet

Model	Product Dim (W/D/H mm)	Voltage/ Frequency (V/Hz)	Power(W)	Capacity(kg/h)	Motor speed (r/min)	Volume of bucket(L)	40 HQ Container loading
HCH8N	680x441x385	220-240/50-60	550	120	1450	5.5	280
HCH14N	760x515x452	220-240/50-60	750	218	1450	10	217

## CURRY SAUSAGE SLICER

- Removable parts are dishwasher safe
- Disassembly of the flap within seconds
- Rotary cutter (hardened and sharpened)
- Removable Quick-Out hood lid
- Practical, maintenance-free machine
- With safety switch (forced break when the cover is removed)
- Air-cooled single phase capacitor motor (suitable for continuous operation)
- Easy to clean



CSH45N



Model	Product Dim (W/D/H mm)	Voltage /Frequency (V/Hz)	Power (W)	Motor Speed(r/min)	Slice Thickness(mm)	40 HQ Container loading
CSH45N	244x189x327	220-240/50,60	135	2650	5-30	1920



CWSH100



- Perfect in workmanship with fully stainless steel
- Evenly sliced and easy to clean
- Steady and slip-resistant
- Base plate with suction pads
- Number of sausage slices: 10 pieces
- Easy to use

Model	Product Dim (W/D/H mm)	Slice Thickness(mm)	40 HQ Container loading
CWSH100	330×189×285	18	3564

## ELECTRIC MEAT TENDERISER



FKA100E



Meat Stripper Attachment  
model:FKA100-1 1pc/ctn  
For fresh meat slicing,Size:  
24x13x12cm,Weight:4.1Kg



Tenderizer Attachment A  
model:FKA100-2 1pc/ctn  
For meat tenderizer,Size:  
24x13x12cm,Weight:3.8Kg



Tenderizer Attachment B  
model:FKA100-3 1pc/ctn  
For meat tenderizer,Size:  
24x13x12cm,Weight:2.9Kg

- Robust and full stainless steel model,no sharp corner
- Meets the hygiene and all safety regulations
- Simple and easy operation and cleaning
- Tenderizer,meat stripper attachments for your choice

Model	Product Dim(W/D/H mm)	Voltage /Frequency (V/Hz)	Power (W)	Capacity(kg/h)	40 HQ Container loading
FKA100E	510x250x520	230/50	350	200	710

# FOOD PROCESSING

## MINCING MACHINE

- Premium quality design for extreme loads
- Silent operation
- Simple operation
- Highly space-saving
- Rustproof
- Easy to clean
- Rubber feet for secure stability



Model	Product Dim (W/D/H mm)	Voltage /Frequency (V/Hz)	Power (W)	Capacity(kg/h)	Motor speed (r/min)	40 HQ Container loading
FWH22	493x220x397	220-240/50,60	1100	220	1450	720
FWH85	472x220x377	220-240/50,60	850	120	1450	720

- Premium quality design for extreme loads
- High-quality stainless steel
- Rubber feet for secure stability
- Simple operation
- Highly space-saving
- Rustproof
- Easy to clean



Model	Product Dim (W/D/H mm)	Capacity (kg/h)	Voltage /Frequency (V/Hz)	Power (W)	40 HQ Container loading
FWFC550	550x220x435	200-240	230/50	550	480

- High quality design for heavy loads
- Stainless steel meat pan with large capacity
- One fine stainless steel plate (4.5 mm)
- One coarse stainless steel plate (7 mm)
- Three stuffing tubes:15, 25 and 35mm
- With meat masher
- Space saving
- Easy to use



Model	Product Dim (W/D/H mm)	Capacity (kg/h)	Voltage /Frequency (V/Hz)	Power (W)	40 HQ Container loading
FWFC450	305x600x415	450-480	230/50	1000	360

- Manual operation by crank handle
- Can be upgraded at any time with FWFC450 for a motorized variant include mincer
- Knife easily removable
- Stable with rubber suction cups
- Easy to clean



Model	Product Dim (W/D/H mm)	Capacity (L)	40 HQ Container loading
FMFC25	570x305x550	28	360

## MEAT MIXER

- High quality design for heavy loads
- Fully welded stainless steel construction
- Two perforated discs for fine and coarse meat processing
- With reverse function
- Space-saving
- Easy to clean



FWFC620  
FWFC350

Model	Product Dim (W/D/H mm)	Capacity (kg/h)	Voltage /Frequency (V/Hz)	Power (W)	40 HQ Container loading
FWFC620	500x436x387	620-680	230/50	1000	368
FWFC350	479x436x387	500-550	230/50	800	368

- Bucket made by stainless steel
- With large bucket capacity
- With strong power



FMH40



FMH60



FMH80  
FMH100

Model	Product Dim (W/D/H mm)	Volume of bucket(L)	Capacity(kg/h)	Voltage /Frequency (V/Hz)	Power (W)	40 HQ Container loading
FMH40	748x457x978	40	64	220-240/50,60	900	116
FMH60	850x647x988	60	96	380-415/50,60	1500	76
FMH80	1006x648x1017	80	128	380-415/50,60	2000	72
FMH100	1149x646x1014	100	160	380-415/50,60	2200	68

## MANUAL MEAT TENDERIZER



MFKHB37

- Ensures a regular thickness of the meat
- The meat remains juicier and tastes better
- Perfect assistant for catering requirements
- Herbs and marinade penetrate deeper into the meat
- Easy to disassemble and clean



MFKHB27

Model	Product Dim(W/D/H mm)	Meat of max(mm)	Number of stainless steel blades	NW/GW(kg)	40 HQ Container loading
MFKHB37	330x185x290	175x25	37	6.8/7.2	882
MFKHB27	280x168x235	125x25	27	5.1/6.5	882

# FOOD PROCESSING

## SAUSAGE STUFFER



WFA3L  
WFA5L  
WFA7L



WFA3S  
WFA5S  
WFA7S

- Light-duty model, easy to be operated.
- Equipped with 4 different funnels, are really the best tools for stuffing any kinds of sausage
- The full stainless steel cylinder, the food approved aluminium piston with special finishing, the solid rack, the precision gears and the accurate manufacturing of all mechanical details ensure a perfect working, the maximum efficiency and long life.

Model	Product Dim(W/D/H mm)	Net capacity (L)	40 HQ Container loading
WFA3L	540×230×200	3	1512
WFA5L	570×230×200	5	1512
WFA7L	580×230×200	7	900
WFA3S	530×300×260	3	840
WFA5S	550×300×260	5	560
WFA7S	660×330×300	7	560

- Absolutely hygienic
- Very user friendly
- Protected against corrosion damages
- Water-repellent and resistant to blood, fat and oil
- Temperature resistant
- Stable beam constructionSpace-saving horizontal design
- Durable, easy-to-clean stainless steel sides and removable steel tilt-out canister
- Enclosed steel gears with 2 speed options and a heavy-duty pressure release valve ensure ultimate control over sausage consistency
- Large rubber feet and a heavy base help prevent movement during use
- Includes 16mm,22mm, 32mm and 38mm stainless steel funnels



WFMFC3L  
WFMFC5L  
WFMFC7L



WFMFC3  
WFMFC5  
WFMFC7

Model	Product Dim(W/D/H mm)	Capacity (L)	40 HQ Container loading
WFMFC3L	430x200x180	3	640
WFMFC5L	550x200x180	5	450
WFMFC7L	680x200x180	7	320
WFMFC3	380x440x540	3	1280
WFMFC5	380x430x650	5	450
WFMFC7	380x430x800	7	420

## SAUSAGE STUFFER

- The model has good product mix, firm and durable, exquisite in workmanship, and provides sausage tube in different sizes, satisfy with customers' needs.
- It is easily to clean, easily to operate.
- Used widely in kitchen, restaurant and many food processing place.



WFMJ7S

Model	Product Dim(W/D/H mm)	40 HQ Container loading
WFMJ7S	785×304×304	610



EWFMH10  
EWFMH12  
EWFMH15

- Foot pedal operation: Free hands at work for maximum flexibility.
- Easy cleaning: The removable filling cylinder ensures easy cleaning.
- The side walls, made of high-quality solid material, provide exceptional stability and ensure that the cylinder is held securely even under heavy use.
- Very stable design (suitable for salami production)
- Operation by the foot pedal or automatic feed
- Filling speed adjustable
- By pressing a button, the cylinder can be moved up automatically



Model	Product Dim(W/D/H mm)	Capacity (L)	Voltage /Frequency (V/Hz)	Power (W)	Motor speed(r/min)	40 HQ Container loading
EWFMH10	370x330x637	10	220-240/50-60	180	1350	650
EWFMH12	370x330x667	12	220-240/50-60	180	1350	600
EWFMH15	370x330x767	15	220-240/50-60	180	1350	550

- Strict with the hygeian standard, stainless steel body.
- Big capacity of cylinder.
- Hydradulic system lifting sausage up and down. low noise and high efficiency.
- Branded electric appliance and hydraulic components ensure good quality and long service life. Conversion switch and foot-switch for safety operation.
- Movable body ensure greater applicability.



WFMHB15  
WFMHB26  
WFMHB35

Model	Product Dim(W/D/H mm)	Voltage /Frequency (V/Hz)	Power (W)	Capacity(kg/h)	40 HQ Container loading
WFMHB15	600x400x1240	220-240/50	750	300	220
WFMHB26	640x485x1240	220-240/50	1100	400	180
WFMHB35	735x560x1240	220-240/50	1500	600	143

# FOOD PROCESSING

## BONE SAW



Bone saw 1660mm  
Max cutting height: 238mm  
KSH1650N



Bone saw 1660mm  
Max cutting height: 245mm  
KSH1650AN



Bone saw 1908mm  
Max cutting height: 240mm  
KSH1900



Bone saw 2020mm  
Max cutting height: 304mm  
KSH2020N



Bone saw 2400mm  
Max cutting height: 355mm  
KSH2400N

- With copper motor
- With sharp saw blade
- With waterproof switch
- With non-slip feet
- Safety feed

Model	Product Dim (W/D/H mm)	Voltage /Frequency (V/Hz)	Power (W)	Table length / width(mm)	40 HQ Container loading
KSH1650N	468x465x876	220-240/50,60	750	440/465	174
KSH1650AN	468x465x876	220-240/50,60	750	440/465	174
KSH1900	565x531x1011	220-240/50,60	750	542/531	114
KSH2020N	596x674x1585	220-240/50,60	1500	565/668	76
KSH2400N	801x743x1732	220-240/50,60	2200	767/738	48

## CAKE SMOOTHING MACHINE



- Machine for smoothing cakes and pies
- Suitable for pastry stores, dessert stores, grocery stores, households and more
- Made of high quality stainless steel and aluminum alloy
- Rotation (left + right) adjustable
- Diameter turntable: 360 mm
- Cake size and height adjustable
- Easy to clean
- Wear and corrosion resistant
- Large and stable turntable

Model	Product Dim (W/D/H mm)	Voltage /Frequency (V/Hz)	Power (W)	Capacity (r/min)	40 HQ Container loading
TGMH	410x550x580	220-240/50,60	60	40-180	278

## HAMBURGER MACHINE

- Patty thickness: 15 – 18 mm
- Manual operation
- Easy to clean
- Simple operation



HMH100  
HMH130  
HMH150



Model	Product Dim(W/D/H mm)	Meat weight per time(g)	40 HQ Container loading
HMH100	290x210x275	99.5	2816
HMH130	290x210x275	168	2816
HMH150	295x210x275	224	1512

## MIXER



Model	Product Dim (W/D/H mm)	Voltage /Frequency (V/Hz)	Power (W)	Capacity(L)	Weight (Kg)	40 HQ Container loading
RMF7B-G	236×409×421	220-240/50,60	350	7	16	560
RMF7B-P	236×409×421	220-240/50,60	350	7	16	560
RMF7B-R	236×409×421	220-240/50,60	350	7	16	560
RMF7B-GR	236×409×421	220-240/50,60	350	7	16	560
RMF7B-Y	236×409×421	220-240/50,60	350	7	16	560
RMF7B-W	236×409×421	220-240/50,60	350	7	16	560
RMF7B-G2	236×409×421	220-240/50,60	350	7	16	560
RMF7B-GG	236×409×421	220-240/50,60	350	7	16	560
RMF7B-MW	236×409×421	220-240/50,60	350	7	16	560
RMF7B-SM	236×409×421	220-240/50,60	350	7	16	560

- Low noise
- Electric machinery over-load protection
- Stepless timing
- Big power and high efficiency



- With copper motor
- With stainless steel bucket
- With non-slip feet

Model	Product Dim (W/D/H mm)	Voltage /Frequency (V/Hz)	Power (W)	Capacity (L)	40 HQ Container loading
RMS7	380×240×405	220-240/50,60	500	7	865
RMH7-W	410×205×395	230/50	800	7	1152

# FOOD PROCESSING

## PLANETARY MIXER

- 7 litre stainless steel bowl
- Integrated safety guard
- Secure bowl locking mechanism



RTK7N



PRMTH5  
PRMTH7

- Suitable for butter, cream, eggs, creams etc.
- With hinged agitator
- The stirring tools are height adjustable
- Stainless steel kettle with handle (removable)
- Practical and versatile to use
- Easy to clean

Model	Product Dim (W/D/H mm)	Capacity(L)	Voltage /Frequency (V/Hz)	Power (W)	40 HQ Container loading
RTK7N	410x230x430	7	220-240/50	325	890
PRMTH5	351x231x412	5	230/50	300	935
PRMTH7	427x250x422	7	230/50	300	935

- Can mix any kind of stuffing with three kinds of beater.
- It adopts planetary mixing principle, painted cast iron body, stainless steel material which come into contact with food.
- Snake-shaped beater/Chequer-shaped beater/Bud-shaped beater,
- Different kinds of stuffing used different beater.
- Different speed for your choose.
- Kneading arm, central column and bowl are made of stainless steel, according to applicable sanitary standards.
- Overload and phase-lacking protection.



PRMH10  
PRMH20  
PRMH30



PRMSH10  
PRMSH20  
PRMSH30

Model	Product Dim (W/D/H mm)	Voltage /Frequency (V/Hz)	Power (W)	Maximum dough capacity (kg)	Mixing Speed(r/min)	40 HQ Container loading
PRMH10	450x366x606	220-240/50,60	450	1.5	110/178/390	288
PRMH20	520x420x760	220-240/50,60	750	4.5	105/180/408	222
PRMH30	545x440x882	220-240/50,60	1100	5.25	105/180/408	150
PRMSH10	452x372x606	220-240/50,60	450	3	110/178/355	288
PRMSH20	530x440x780	220-240/50,60	1100	6	104/187/365	222
PRMSH30	546x440x852	220-240/50,60	1100	6	104/187/365	150



PLRM35H  
PLRM40H  
PLRM60H



- Belt system, motor overload protection.
- High quality Schneider appliance switches included.
- The automotive spray painting avoids fading for years.
- The tin bronze gear maintains good wear-resistance.
- The pure copper motor provides stable performance, high torque and low noise.
- The premium grease seal ensures seamless sealing and prevents oil leakage.
- Cover opening protection and Bowl Sliding protection ensure the operator's safety. The non-welding brushed stainless steel bowl adopts one-step molding technique and enhances durability.

Model	Product Dim (W/D/H mm)	Voltage /Frequency (V/Hz)	Power (W)	Maximum dough capacity (kg)	Mixing Speed(r/min)	40 HQ Container loading
PLRM35H	630x562x1011	220-240/50,60	1125	6.75	80/160/388	150
PLRM40H	645x562x1011	220-240/50,60	1312	9	80/160/388	150
PLRM60H	770x625x1250	380/50	2250	12	74/155/388	43

## DOUGH KNEADING MACHINE

- Equipped with a microswitch controller for safety
- Heavy duty: Actual flour weight is the maximum kneading capacity
- High-efficiency
- Mixers and bowl revolves simultaneously to provide speed and better results
- Comes with safety covers
- Stainless steel bowl



STM60

Model	Product Dim (W/D/H mm)	Voltage/ Frequency (V/Hz)	Power of the spiral motor(W)	Power of the bowl motor(W)	Maximum dough capacity (kg)	Maximum flour capacity (kg)	Bowl volume(L)	Bowl diameter(mm)	40 HQ Container loading
STM60	1210×720×1430	380-440/50,60	3700/2000	550	60	37.5	115	670	28
STM80	1210×720×1430	380-440/50,60	2600/5200	550	80	50	129	670	28
STM120	1240×785×1500	380-440/50,60	3700/7500	750	120	75	189	750	23
STM160	1425×946×1715	380-440/50,60	10000/5500	1100	160	100	260	910	14
STM200	1425×946×1715	380-440/50,60	12000/7500	1100	200	125	306	910	14

## BAKERY DOUGH SHEETER



TMK520B



TMK520L

Model	Product Dim (W/D/H mm)	Voltage/ Frequency (V/Hz)	Power (W)	Working Width(mm)	Conveyer Table Length(mm)	Gap between Rollers(mm)	Conveyer belt size(mm) W/L	40 HQ Container loading
TMK520B	2080x880x620	380/50	400	500	990	0.3-35	500x2000	56
TMK520L	2950x880x1170	380/50	750	500	1190	0.3-35	500x2400	28

## HORIZONTAL CUTTER STAND

- With copper motor
- Stainless steel body and knives
- Highly close to manual knife chopping
- With waterproof switch
- With non-slip feet



HCH209



HCH2010

Model	Product Dim (W/D/H mm)	Volume of bucket(L)	Capacity(kg/h)	Voltage /Frequency (V/Hz)	Power (W)	40 HQ Container loading
HCH209	899x707x926	20	5-10	220-240/50-60	1500	56
HCH2010	907x699x1025	20	5-10	220-240/50-60	1500	56

# FOOD PROCESSING

## HAND BLENDER

- Professional equipment particularly suited for ice cream shops, confectionery, restaurants and hotels etc.
- Elegant body design made from plastic, heavy duty hand mixer available in 4 motor sizes to meet the demands of any kitchens.
- 280W, 450W, 650W and 850W ventilated motors, thermal overload protection and variable speed control switch.
- Ergonomic handle for comfortable use.
- Full stainless steel, high performance blade, all food contact parts in stainless steel.



Model	Product Dim(W/D/H mm)	Voltage /Frequency (V/Hz)	Power (W)	Speed (r/min)	40 HQ Container loading
STHMMA16N	544x75x75	100-120/60 220-240/50	280	20000	6300
STHMMLA16N	544x75x75	100-120/60 220-240/50	280	6000-20000	6300
STMA45N	359x190x91	100-120/60 220-240/50	450	16000	2520
STMLA45N	359x190x91	100-120/60 220-240/50	450	4000-16000	2520
STMA65N	396x220x116	100-120/60 220-240/50	650	18000	2205
STMLA65N	396x220x116	100-120/60 220-240/50	650	8000-18000	2205
STMA85N	396x220x116	100-120/60 220-240/50	850	18000	2205
STMLA85N	396x220x116	100-120/60 220-240/50	850	8000-18000	2205



STMLA45N, STMLA65N, STMLA85N  
for choice



RBA25



WHMMA



THMMA

Model	Product Dim(W/D/H mm)	40 HQ Container loading
RBA25	118x118x388	2940
WHMMA	270x89x65	25200
THMMA	600x400x50	12600

## SPINDLE MIXER

- Ideal for the preparation of smoothies, milkshakes and cocktails.
- Anti-slip feet for a safe stand
- Compact and space-saving
- Long service life is guaranteed due to the stainless steel drive
- shaft Corrosion resistant and scratch resistant
- Precision motor minimises vibrations



Model	Product Dim(W/D/H mm)	Voltage /Frequency (V/Hz)	Power (W)	Net Volume(L)	40 HQ Container loading
SPMET1B	230x230x495	220-240/50,60	300	0.9	1280
SPMET1W	230x230x495	220-240/50,60	300	0.9	1280

- Ideal for the preparation of smoothies, milkshakes and cocktails.
- Anti-slip feet for a safe stand
- Compact and space-saving
- Long service life is guaranteed due to the stainless steel drive
- shaft Corrosion resistant and scratch resistant
- Precision motor minimises vibrations



Model	Product Dim(W/D/H mm)	Voltage /Frequency (V/Hz)	Power (W)	Net Volume(L)	40 HQ Container loading
SPMET1	230x230x495	220-240/50,60	300	0.9	1280
SPMET2	330x160x500	220-240/50,60	600	0.9+0.9	1280

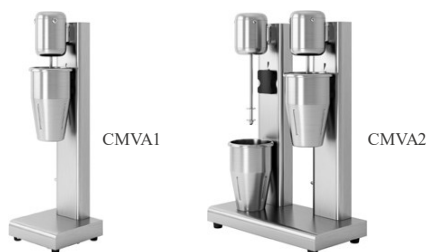

- 2 speed levels
- Safety microswitch
- High performance with low energyconsumption
- With non-slip rubber feet
- Ideal for milkshakes, protein shakes, cocktails, etc.

Model	Product Dim(W/D/H mm)	Voltage/ Frequency (V/Hz)	Power (W)	Net Volume(L)	40 HQ Container loading
CMVA1	170x170x510	230/50	80	1	1958
CMVA2	360x170x510	230/50	80+80	1+1	968

# FOOD PROCESSING

## CHURRO MACHINE



Model	Product Dim (W/D/H mm)	Filling Volume(L)	NW/GW(kg)	40 HQ Container loading
CHMNP5	190x130x590	5	10.2/10.82	612
CHMNP3	180x130x580	3	8.42/9.36	952
UGCHMNP44	440x550x380	/	3.4/3.98	5568
UGCHMNP76	700x550x380	/	3.8/4.52	5568
UGVCHMNP76	700x580x380	/	3.88/4.64	5568

## MANUAL DONUT TOOL



Model	Product Dim (W/D/H mm)	NW/GW(kg)	40 HQ Container loading
DMMNP	160x160x390	0.8/1	1568

## HOPPER



Model	Product Dim (W/D/H mm)	NW/GW(kg)	40 HQ Container loading
FMCNP1	190x190x400	0.8/1	3380
FMNP1	130x250x220	0.45/0.5	6300
FMNP04	100x140x150	0.3/0.5	16354

## HOPPER



OFTH125

Model	Product Dim (W/D/H mm)	NW/GW(kg)	40 HQ Container loading
OFTH125	Φ135x270	0.42/7.3	8114



CFTH15



CFTH18A



CFTH18AT

Model	Product Dim (W/D/H mm)	NW/GW(kg)	40 HQ Container loading
CFTH15	Φ170x H:255	1/10.3	4968
CFTH18A	Φ194x H:265	0.8/9.06	4968
CFTH18AT	Φ194x H:295	0.91/9.9	4968

## FILLING MACHINE



FMTNP

Model	Product Dim (W/D/H mm)	NW/GW(kg)	40 HQ Container loading
FMTNP	80x200x450	0.9/1	5610



FMSA10



FMMSA10

- Various applications - for portioning creams, oils, or e.g. pastes.
- Adjusting the filling quantity by means of a rotary knob
- Funnel and the filling elements made of stainless steel
- Filling accuracy: +/- 1%
- Easy to operate
- Easy to clean

Model	Product Dim(W/D/H mm)	Product category	Capacity (L)	Filling range(ml)	40 HQ Container loading
FMSA10	285x285x720	Pneumatic filling machine	10	0-50	756
FMMSA10	285x285x720	Manual type filling machine	10	0-50	756

# FOOD PROCESSING

## ELECTRIC OIL PRESS



EOPMCH-Gold



EOPMCH-Grey

- Comes with a safety protection net
- 360-degree anti-scalding design
- Adjustable temperature between 0 °C to 300 °C
- Made of stainless steel, with a beautiful appearance and unique design

Model	Product Dim(W/D/H mm)	Voltage /Frequency (V/Hz)	Power (W)	Capacity (kg/h)	40 HQ Container loading
EOPMCH-Gold	190x500x290	220-240/50-60	1800	5	1080
EOPMCH-Grey	190x500x290	220-240/50-60	1800	5	1080

## JUICE EXTRACTOR



FSET6



FSET28

Model	Product Dim(W/D/H mm)	Voltage /Frequency (V/Hz)	Power (W)	40 HQ Container loading
FSET6	300x190x340	220-240/50,60	180	1280
FSET28	400x250x460	220-240/50,60	600	1280



FSK200

- Casting aluminum body
- Waterproof motor block
- 3 removable suzezer cones



FSK300

- Simple design for easy operation
- Stainless steel with mirror polish as professional appearance



FSK400

- Suitable for fruit and vegetable
- Microswitch safety system
- Overload switch
- Simple design for easy operation
- Separate juice from pericarp

Model	Product Dim(W/D/H mm)	Voltage /Frequency (V/Hz)	Power (W)	40 HQ Container loading
FSK200	218x308x354	220-240/50,60	180	1300
FSK300	287x212x470	220-240/50,60	230	1180
FSK400	390x270x500	220-240/50,60	600	800

## FOOD MIXER

- BPA-free
- Automatic shut-off function in case of overheating
- Quiet operation
- Powerful motor
- Adjustable revs
- Very simple manual operation
- Long service life
- Easy to clean
- Containers are not dishwasher safe
- Plastic casing



FMK1500

Model	Product Dim(W/D/H mm)	Voltage /Frequency (V/Hz)	Power (W)	Net Capacity(L)	Best (r/min)	40 HQ Container loading
FMK1500	185×240×520	220-240/50,60	1500	2	25000-28000	1620

- Large LCD screen.Sealing strip Sound Cover
- Professional sound insulation cover design
- Automatic memory of the last usage programs
- 185kinds of pro modes
- Automatic shut Off for Overload Protection
- No Plunger Needed.Optional Jar magnet device
- Special heat treatment Stainless steel Blades from Japan
- Stainless steel Double-bearings
- Double waterproof bearing chamber structure



BMK2-1500



BMK2-2200

- Variable Speed control,Pulse and power switch
- Automatic shut Off for Overload
- Protection Optional Plunger Needed

Model	Product Dim(W/D/H mm)	Voltage /Frequency (V/Hz)	Power (W)	Net Capacity(L)	Rabbit Size(mm)	Best (r/min)	40 HQ Container loading
BMK2-1500	220×260×500	220-240/50,60	1500	2	150x150x150	28000	996
BMK2-2200	220×240×480	220-240/50,60	1500	2	140x140x140	28000-30000	1176

## ORANGE SQUEEZER

- Stainless steel water tray
- Powerful and stable motor
- Strengthen protection switch
- Automatic feeding fruit
- Automatic tap control
- Easy operation and easy cleaning



OPB20E



OPET20

- Automatic fruit supply
- Particularly suitable for buffets and restaurants
- Strong and reliable
- Stainless steel housing
- Powerful motor
- Easy to use
- Easy to clean

Model	Product Dim(W/D/H mm)	Voltage /Frequency (V/Hz)	Power (W)	Size of orange required(mm)	Output per minute	40 HQ Container loading
OPB20E	400x450x900	220-240/50,60	200	Φ60-80	20	152
OPET20	640x450x780	230/50	120	Φ40-80	20	160

# FOOD PROCESSING

## VACUUM MACHINE



VMKH-300



VMKH-400Z



VMKH-4002



VMKH-500

- Multi-language
- User-friendly
- Durable electric units
- 3mm thickness
- Formed by mould
- Hings absorb shocks
- Long life
- Not easily deformation
- Seamless
- Safty for operator

Model	Product Dim(W/D/H mm)	Voltage /Frequency (V/Hz)	Power (W)	Pump Capacity(m <sup>3</sup> /h)	Sealing Length(mm)	Sealing Width(mm)	Vacuum Chamber Depth(mm)	40 HQ Container loading
VMKH-300	385x510x370	230/50	370	10	290	5	55	560
VMKH-400Z	500x540x480	230/50	900	20	390	10	65	250
VMKH-4002	500x540x905	230/50	900	20	390	10	65	160
VMKH-500	590x645x920	230/50	900	20	490	10	70	125



VGFW2018



- Sealers Vacuum Food Saver.Press it and automatically vacuuming
- Press the button to seal bag without vacuuming
- You can choose the dry indication for solid food items and the moist indication for poached food.
- Keep food fresh up to 5 times longer than other storage methods

Model	Product Dim(W/D/H mm)	Pump Vacuum Liter(L/m)	Voltage /Frequency (V/Hz)	Power (W)	Sealing Length(mm)	Sealing Width(mm)	Lock	40 HQ Container loading
VGFW2018	390×150×67	12	110-240/50,60	110	320	3	Handy Press	5923

## MOBILE GLASS WASHER



MGSX600

- Easy to install and use
- Water saving, more than 70%
- Zero power consumption, energy-saving and environmental
- Perfect washing performance with cold water
- Will not broken the glass
- Will clean the lipstick and other besmirch easily and clearly
- Suitable for all types of glass
- Esthetical designed
- Compact and light, you can put it anywhere

Model	Product Dim (W/D/H mm)	Production Capacity(pcs/hour)	40 HQ Container loading
MGSX600	380x200x360	600	1920

## DISH WASHER

- Body made by stainless steel
- 360 degree rotating spray
- Continuous high temperature disinfection at 80-85 degrees Celsius
- Compact and space-saving



Model	Product Dim(W/D/H mm)	Capacity(basket/h)	Voltage /Frequency (V/Hz)	Power (W)	Volume of bucket (L)	40 HQ Container loading
DH300	476x550x720	30	380-415/50,60	5550	20	219
DH3050	600x610x820	30	380-415/50,60	7000	20	102
DH430	706x873x1473	60	380-415/50,60	14500	33	26

## HONEY EXTRACTOR

- Powerful electric motor with different speed options
- Made of stainless steel
- Suitable for frame size: 23,50 mm x 44 mm x 48,80 mm
- With 3 height adjustable feet
- Easy mounting
- Easy to use



Model	Product Dim (W/D/H mm)	Net capacity (L)	Voltage /Frequency (V/Hz)	Rated Speed(r/min)	Power (W)	40 HQ Container loading
HSEWU3	380x380x605	90	220-240/50	180	140	168

## SESAME PEANUT BUTTER MACHINE

- Sesame and peanut butter machine is a machine that can grind tahini paste, peanut butter, soybean milk, rice milk, starch pulp and chemical raw material pulp.
- It has the advantages of small size, easy handling, easy operation, low noise, high efficiency, fine grinding, low temperature, no heat grinding and so on, and is the ideal machine to replace the traditional stone grinding.



Model	Product Dim(W/D/H mm)	Voltage /Frequency (V/Hz)	Power (W)	Capacity(kg/h)	40 HQ Container loading
SMHB	320x320x700	220-240/50	1100	15	850

# FOOD PROCESSING

## POULTRY PLUCKER



- Poultry plucking machine for quails, pigeons, chicks, etc.
- Without integrated water flushing.
- With spring ejection chute to keep the springs in one place
- Hand protection for safe operation
- Ideal for use in the catering industry, agriculture or even in slaughterhouses
- This plucker is perfect for plucking quail, pigeons, chicks and smaller birds
- Housing made of high quality stainless steel
- Easy to clean

Model	Product Dim(W/D/H mm)	Voltage /Frequency (V/Hz)	Power (W)	Capacity(pcs/min)	Engine Speed (r/min)	40 HQ Container loading
GRMWX119	347x347x670	220-240/50,60	1500	1-2	1350	540
GRMWX136	570x570x950	220-240/50,60	1500	3-4	1400	120
GRMWX184	660x660x950	220-240/50,60	1500	5-6	1400	120
GRMWX211	860x860x1027	220-240/50,60	2200	8-10	1400	48

## POULTRY PLUCKER AND SCALDER

- Plucking machine with integrated scalding tank for poultry
- Ideal for use in the catering industry, agriculture or even in slaughterhouses With digital thermostat
- Temperature: 30 °C to 110 °C
- With automatic temperature limiter
- With water inlet & water valve on the side wall
- Easy to move due to the 4 attached wheels
- With spring ejection chute to keep the springs in one place
- Housing made of high quality stainless steel



GRMWX50  
GRMWX55  
GRMWX60

Model	Product Dim(W/D/H mm)	Voltage /Frequency (V/Hz)	Power (W)	Capacity(pcs/min)	40 HQ Container loading
GRMWX50	1020x554x955	220-240/50,60	1500	3-4	60
GRMWX55	1122x602x955	220-240/50,60	1500	4-5	60
GRMWX60	1221x652x955	220-240/50,60	1500	5-6	54

## SCALDING KETTLE POULTRY

- Scalding kettle for poultry
- Ideal for use in the catering industry, agriculture or even in slaughterhouses Brewing time: 70-180 seconds
- With digital thermostat
- With automatic temperature limiter
- With water inlet and water valve on the side wall
- Housing made of high quality stainless steel



BKWX70

Model	Product Dim(W/D/H mm)	Voltage /Frequency (V/Hz)	Power (W)	Capacity(L)	Operation temperature(°C)	overheat protection temperature(°C)	40 HQ Container loading
BKWX70	450x350x670	220-240/50,60	1800	70	30~110	130	506

## HAND DRYER

- There is blue half circle LED light to guide user to air flow.
- Customized ON/OFF switch for heat element.
- 360° revolving air nozzle.
- 60 Seconds continuous running automatic cut-off protection.
- Built in electronic infrared sensor



- Space saving and the jet hand dryer protrudes less than 195mm from the wall.
- Brushless powerful motor and HEPA filter
- to create clean air without bacteria.
- Dry hands in 7 seconds by super-powered Jet air.
- ECO friendly and cost saving.
- High traffic and heavy duty hand dryer.

Model	Product Dim(W/D/H mm)	Voltage /Frequency (V/Hz)	Power (W)	Air temperature (°C)	Air speed(m/s)	Drying time(s)	Continuous working time(s)	40 HQ Container loading
EHTDKE15	262x208x231	220-240/50,60	2300	45	26	15-20	60	2464
EHTKE15	262x208x231	220-240/50,60	2300	45	26	15-20	60	2464
HTEKE7	297x195x671	220-240/50,60	1650	40	130	7-9	25	832
HTWKE7	297x195x671	220-240/50,60	1650	40	130	7-9	25	832

## SHOE POLISHER

- With two detachable soft brushes
- With replaceable shoe wax bottle
- With one hard brush



SPMFE

Model	Product Dim(W/D/H mm)	Voltage /Frequency (V/Hz)	Power(W)	With Handle or Not	40 HQ Container Loading
SPMFE	400X240X245	230/50	120	Yes	1706

## CAN OPENER

- Safe design, does not hurt hands
- Easy to operate, efficient and fast
- Suitable for cans of different heights



DOH750  
DOH500

Model	Product Dim(W/D/H mm)	Net weight (kg)	Gross weight (kg)	40 HQ Container loading
DOH750	750x200x120	1.8	13 (8pcs/carton)	5712
DOH500	500x200x120	1.55	11 (8pcs/carton)	8190

# FOOD PROCESSING

## JUICE EXTRACTOR MANUALLY

- Energy saving
- Ergonomic handle
- Stainless steel pressing cone
- Long rubber handle for better leverage
- High stability due to U-shaped design of the foot
- Easy to use
- Easy to clean



FSPSH-SI



FSPSH-W



FSPSH-S



FSPSH-B

Model	Product Dim(W/D/H mm)	Color	40HQ Container loading
FSPSH-SI	185x250x490	Silver	2052
FSPSH-W	185x250x490	White	2052
FSPSH-S	185x250x490	Black	2052
FSPSH-B	185x250x490	Bronze	2052

## KNIFE SHARPENER

- Low motor sound
- There are rough grinding, fine grinding, and specialized cutting edges for grinding scissors
- Simple and durable appearance



MSSRSS



MSSES

- Simple and durable appearance, with stainless steel elements showing a more high-end atmosphere
- There are rough grinding, fine grinding, and specialized cutting edges for grinding scissors

Model	Product Dim(W/D/H mm)	Voltage /Frequency (V/Hz)	Power(W)	Capacity(pcs/day)	40 HQ Container Loading
MSSRSS	220x88x73	100-240/50,60	50	1500	9856
MSSES	218x66x77	100-240/50,60	12	1500	12800

## MANUAL STAINLESS STEEL SAUSAGE CLIPPER

- Entirely made of high quality stainless steel
- Desktop unit
- Diameter: 45 - 120 mm
- Simple, manual operation via lever
- Strong closure of the sausage filling
- Leakage of the filling impossible
- Easy to clean



MWCH1

Model	Product Dim(W/D/H mm)	Package Dim(W/D/H mm)	NW/GW(kg)	40 HQ Container loading
MWCH1	400x180x610	425x220x660	10.5/11.5	1360

## ICE CRUSHER

- Material: Plastic Shell And Aluminium Hopper
- Simple design for easy operation



- Base made in aluminum alloy
- Stainless steel container
- Strong cutlery steel blade
- Safety microswitch included
- High capacity for professional use
- Ventilated motor with gear transmission for prolonged use
- The machine is designed and produced according to international standards for safety and hygiene.

Model	Product Dim(W/D/H mm)	Speed(r/min)	Voltage /Frequency (V/Hz)	Power (W)	40 HQ Container loading
TECK03	190x420x290	1450	230/50	300	1600
ECTA80	328x197x533	1000	220-240/50	200	960

## FOOD TRAILER

- Easy to move, you can move anywhere at any time
- The trailer is fully equipped, and the corresponding equipment can be controlled according to the size of the vehicle. The appearance of the atmosphere is beautiful, good-looking and practical to attract more customer
- With food trailer as the carrier, save rental rent and work freely
- Low operating costs, but large equity
- Have lower staffing costs.
- Require low initial investment.
- Involves relatively low operation cost.
- Can experiment with location.



Model	Product Dim(W/D/H mm)	Net weight(kg)	Driving type	40 HQ Container loading
MFY-FF2-E	4000x2100x2380	1500	Trailer	2
MFY-FF2-G	2200x1600x2350	450	Trailer	7
MFY-FF2-B	3800x2000x2350	1200	Trailer	3

# NEUTRAL PRODUCT





- Work table
- Top shelf
- Heating light
- Drawer block - base module
- Rubbish bin - substructure module
- Stainless steel chopping block
- Meat table
- Sink unit with floor base
- Dishwasher sink
- Hand wash sink
- Stainless steel sink cabinet
- Dishwasher cabinet
- Stainless steel work cabinet
- Beverage dispenser base cabinet
- Substructure
- Rubbish bin with roll container
- Flour trolley
- Litter bin with lift lid
- Drawer cabinet
- Corner cabinet
- Corner work table
- Tableware cabinet
- Wall cabinet
- Self assembly
- Stainless steel cash desk
- Wall-hanging cabinet
- Exhaust hood no blower with filter
- Flame protection filter
- Food shelf
- Wall shelves
- Stainless steel shelf
- Trolley
- Stainless steel foldable work table
- Stainless steel cutlery tray
- Wall shelf spice shelf
- Cup dispenser
- S/s pet grooming bathtub
- Coffee grounds drawer
- Insect killer
- Stainless steel gn container
- Milk jug with lid



# STAINLESS STEEL

## STAINLESS STEEL WORK TABLE- WITH BASE WITHOUT UPSTAND

- High quality stainless steel
- Rounded edges
- Ideal working height
- Very high load capacity
- Headroom available
- Ideal for individual drawers, as well as drawer tables and waste bins can be installed
- Easy to clean



ATK147

### 600 series

Model	Product Dim (W/D/H mm)	40 HQ Container loading
ATK66	600x600x870	683
ATK76	700x600x870	683
ATK86	800x600x870	717
ATK106	1000x600x870	587
ATK126	1200x600x870	490
ATK146	1400x600x870	423
ATK156	1500x600x870	397
ATK166	1600x600x870	372
ATK186	1800x600x870	332
ATK206	2000x600x870	300

### 700 series

Model	Product Dim(W/ D/H mm)	40 HQ Container loading
ATK67	600x700x870	597
ATK77	700x700x870	597
ATK87	800x700x870	617
ATK107	1000x700x870	511
ATK127	1200x700x870	428
ATK147	1400x700x870	370
ATK157	1500x700x870	345
ATK167	1600x700x870	324
ATK187	1800x700x870	290
ATK207	2000x700x870	261

### 800 series

Model	Product Dim(W/ D/H mm)	40 HQ Container loading
ATK108	1000x800x870	409
ATK128	1200x800x870	343
ATK148	1400x800x870	295
ATK158	1500x800x870	276
ATK168	1600x800x870	259
ATK188	1800x800x870	230
ATK208	2000x800x870	208

## STAINLESS STEEL WORK TABLE -WITH BASE WITH UPSTAND

- High quality stainless steel
- Rounded edges
- Very high load capacity
- Headroom available
- Ideal for individual drawers, as well as drawer tables and waste bins can be installed
- Easy to clean



ATK147A

### 600 series

Model	Product Dim (W/D/H mm)	40 HQ Container loading
ATK66	600x600x870+100	526
A ATK76A	700x600x870+100	526
ATK86	800x600x870+100	550
A ATK106A	1000x600x870+100	452
ATK126	1200x600x870+100	380
A ATK146A	1400x600x870+100	327
ATK156	1500x600x870+100	306
A ATK166A	1600x600x870+100	287
ATK186A	1800x600x870+100	256
ATK206A	2000x600x870+100	231

### 700 series

Model	Product Dim (W/D/H mm)	40 HQ Container loading
ATK67	600x700x870+100	461
A ATK77A	700x700x870+100	461
ATK87	800x700x870+100	477
A ATK107A	1000x700x870+100	394
ATK127	1200x700x870+100	330
A ATK147A	1400x700x870+100	285
ATK157	1500x700x870+100	267
A ATK167A	1600x700x870+100	251
ATK187A	1800x700x870+100	224
ATK207A	2000x700x870+100	202

### 800 series

Model	Product Dim (W/D/H mm)	40 HQ Container loading
ATK108	1000x800x870+100	390
A ATK128A	1200x800x870+100	327
ATK148	1400x800x870+100	281
A ATK158A	1500x800x870+100	262
ATK168	1600x800x870+100	246
A ATK188A	1800x800x870+100	219
ATK208	2000x800x870+100	198
A		

## STAINLESS STEEL WORK TABLE - WITH SUPPORT WITHOUT SHELF AND UPSTAND



ATK167V

- High quality stainless steel
- Easy to assemble
- Without the splash back can be spliced together

### 600 series

Model	Product Dim (W/D/H mm)	40 HQ Container loading
ATK106	1000x600x870	587
ATK126V	1200x600x870	490
ATK146	1400x600x870	423
ATK156V	1500x600x870	397
ATK166	1600x600x870	372
ATK186V	1800x600x870	332
ATK206V	2000x600x870	300

### 700 series

Model	Product Dim (W/D/H mm)	40 HQ Container loading
ATK107	1000x700x870	511
ATK127V	1200x700x870	428
ATK147	1400x700x870	370
ATK157V	1500x700x870	345
ATK167	1600x700x870	324
ATK187V	1800x700x870	290
ATK207V	2000x700x870	261

## STAINLESS STEEL WORK TABLE - WITHOUT SHELF WITH SUPPORT AND UPSTAND



ATK167AV

- High quality stainless steel
- Easy to assemble
- Height adjustable 870-970mm
- With the splash back to prevent water from splashing onto the wall

### 600 series

Model	Product Dim (W/D/H mm)	40 HQ Container loading
ATK106A V	1000x600x870+100	587
ATK126AV	1200x600x870+100	490
ATK146A V	1400x600x870+100	423
ATK156AV	1500x600x870+100	397
ATK166A V	1600x600x870+100	372
ATK186AV	1800x600x870+100	332
ATK206A V	2000x600x870+100	300

### 700 series

Model	Product Dim (W/D/H mm)	40 HQ Container loading
ATK107A V	1000x700x870 +100	394
ATK127AV	1200x700x870 +100	330
ATK147A V	1400x700x870 +100	285
ATK157AV	1500x700x870 +100	267
ATK167A V	1600x700x870 +100	251
ATK187AV	1800x700x870 +100	224
ATK207A V	2000x700x870 +100	202

# STAINLESS STEEL

## STAINLESS STEEL WORK TABLE - WITH BASE & UPSTAND AT THE BACK + RIGHT

- High quality stainless steel
- Easy to assemble
- Can be added with layers to make three layers
- The undershelf can be replaced by a support, front
- opening Height adjustable 870-970mm
- Two choices with and without splash back: with the splash back to prevent water from splashing onto the wall,
- without the splash back can be spliced together



ATK66AA

Model	Product Dim(W/D/H mm)	40 HQ Container loading
ATK66A	600x600x870+100	526
ATK77AA	700x700x870+100	461

## TOP SHELF

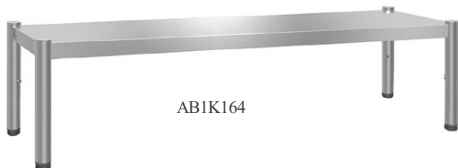

AB1K164

- High quality stainless steel
- Rounded edges
- Very high load capacity
- 2 adjustable tier(s)
- Easy to clean
- Soundproof footplates
- Can be installed with heating light



AB2K147

### 400 series

Model	Product Dim (W/D/H mm)	40 HQ Container loading
AB1K8	800x370x400	3227
4 AB1K104	1000x370x400	2536
AB1K12	1200x370x400	2152
4 AB1K144	1400x370x400	1821
AB1K16	1600x370x400	1614
4 AB1K184	1800x370x400	1420
AB1K20	2000x370x400	1291
4		

### 700 series

Model	Product Dim (W/D/H mm)	40 HQ Container loading
AB2K8	800x370x700	2029
7 AB2K107	1000x370x700	1614
AB2K12	1200x370x700	1365
7 AB2K147	1400x370x700	1164
AB2K16	1600x370x700	1029
7 AB2K187	1800x370x700	910
AB2K20	2000x370x700	816
7		

# HEATING LIGHT

Heating light 2 Lights



KBK7-2  
KBK9-2

Heating light 3 Lights



KBK11-3  
KBK13-3

Heating light 4 Lights



KBK15-4  
KBK17-4

Heating light 5 Lights



KBK19-5

- High quality heating elements
- Infrared heating
- Easy to be installed with over shelf

Model	Product Dim(W/D/H mm)
KBK7-2	726x120x80
KBK9-2	926x120x80
KBK11-3	1126x120x80
KBK13-3	1326x120x80
KBK15-4	1526x120x80
KBK17-4	1726x120x80
KBK19-5	1926x120x80

# DRAWER BLOCK - BASE MODULE



SE1K46  
SE1K47  
SE1K48



ST2K46  
ST2K47  
ST2K48



ST3K46  
ST3K47  
ST3K48



- High quality stainless steel
- Easy to assemble with working table
- Silent pulley for drawers

- High quality stainless steel
- Easy to assemble with working table
- Silent pulley for drawers
- Different drawers that can be stored separately

Model	Product Dim(W/D/H mm)	40 HQ Container loading
SE1K4	400x560x150	1520
6 SE1K47	400x660x150	1296
SE1K4	400x760x150	1125
8 ST2K46	400x560x585	420
ST2K47	400x660x585	360
ST2K48	400x760x585	280
ST3K46	400x560x585	420
ST3K47	400x660x585	360
ST3K48	400x760x585	280

# STAINLESS STEEL

## RUBBISH BIN - SUBSTRUCTURE MODULE



MEK46  
MEK47  
MEK48

- High quality stainless steel
- Easy to assemble with working table

Model	Product Dim(W/D/H mm)	40 HQ Container loading
MEK46	400x560x585	420
MEK47	400x660x585	360
MEK48	400x760x585	280

## STAINLESS STEEL CHOPPING BLOCK



FTK55

- Body made of high quality stainless steel
- 80mm Polyethylene worktop
- Perfect for processing: meat, vegetables, fish
- Easy to clean

Model	Product Dim(W/D/H mm)	40 HQ Container loading
FTK55	500x500x870	271

## MEAT TABLE



FTK166

- Body made of high quality stainless steel
- Polyethylene work surface
- Perfect for processing: meat, vegetables, fish
- Easy to clean



Model	Product Dim (W/D/H mm)	40 HQ Container loading
FTK126	1200x600x870	490
FTK146	1400x600x870	423
FTK166	1600x600x870	372
FTK186	1800x600x870	332
FTK206	2000x600x870	300

Model	Product Dim (W/D/H mm)	40 HQ Container loading
FTK127	1200x700x870	430
FTK147	1400x700x870	370
FTK167	1600x700x870	326
FTK187	1800x700x870	290
FTK207	2000x700x870	261

## STAINLESS STEEL SINK - WITH BASE - 1 BASIN ON THE LEFT



- High quality stainless steel
- Easy to Maintain & Clean, this sink adopts streamlined rounded corners and edge design, convenient for daily washing

### 600 series

Model	Product Dim(W/D/H mm)	40 HQ Container loading
STK106BL1	1000x600x870+100	226
STK126BL1	1200x600x870+100	219
STK146BL1	1400x600x870+100	189

### 700 series

Model	Product Dim(W/D/H mm)	40 HQ Container loading
STK107BL1	1000x700x870+100	201
STK127BL1	1200x700x870+100	169
STK147BL1	1400x700x870+100	145

## STAINLESS STEEL SINK - WITH BASE - 1 BASIN ON THE RIGHT



- High quality stainless steel
- Easy to assemble
- Top is stretch, easy to clean
- Bowl is stretch: dedicated custom molds for bowl and drainage more easily
- Grooved board
- Height adjustable 870-970mm

### 600 series

Model	Product Dim(W/D/H mm)	40 HQ Container loading
STK106BR1	1000x600x870+100	226
STK126BR1	1200x600x870+100	219
STK146BR1	1400x600x870+100	189

### 700 series

Model	Product Dim(W/D/H mm)	40 HQ Container loading
STK107BR1	1000x700x870+100	201
STK127BR1	1200x700x870+100	169
STK147BR1	1400x700x870+100	145

## STAINLESS STEEL SINK - WITH BASE - 2 BASINS ON THE LEFT



- High quality stainless steel
- Easy to assemble
- Top is stretch, easy to clean
- Bowl is stretch: dedicated custom molds for bowl and drainage more easily
- Grooved board
- Height adjustable 870-970mm

### 600 series

Model	Product Dim (W/D/H mm)	40 HQ Container loading
STK146BL	1400x600x870+100	189
<sup>2</sup> STK166BL2	1600x600x870+100	166
STK186BL	1800x600x870+100	148
<sup>2</sup> STK206BL2	2000x600x870+100	134

### 700 series

Model	Product Dim (W/D/H mm)	40 HQ Container loading
STK147BL	1400x700x870+100	164
<sup>2</sup> STK167BL2	1600x700x870+100	128
STK187BL	1800x700x870+100	114
<sup>2</sup> STK207BL2	2000x700x870+100	103

# STAINLESS STEEL

## STAINLESS STEEL SINK - WITH BASE - 2 BASINS ON THE RIGHT



- High quality stainless steel
- Easy to assemble
- Top is stretch, easy to clean
- Bowl is stretch: dedicated custom molds for bowl and drainage more easily
- Grooved board
- Height adjustable 870-970mm

### 600 series

Model	Product Dim (W/D/H mm)	40 HQ Container loading
STK146BR	1400x600x870+100	189
STK166BR2	1600x600x870+100	166
STK186BR	1800x600x870+100	148
STK206BR2	2000x600x870+100	134

### 700 series

Model	Product Dim (W/D/H mm)	40 HQ Container loading
STK147BR	1400x700x870+100	164
STK167BR2	1600x700x870+100	128
STK187BR	1800x700x870+100	114
STK207BR2	2000x700x870+100	103

## STAINLESS STEEL SINK - WITH BASE - 2 BASINS IN THE MIDDLE

- High quality stainless steel
- Easy to assemble
- Top is stretch, easy to clean
- Bowl is stretch: dedicated custom molds for bowl and drainage more easily
- Grooved board
- Height adjustable 870-970mm



STK206BM2

Model	Product Dim(W/D/H mm)	40 HQ Container loading
STK206BM2	2000x600x870+100	134
STK207BM2	2000x700x870+100	103

## STAINLESS STEEL SINK - WITH BASE - 1 BASIN



STK66BM1

- High quality stainless steel
- Easy to assemble
- Top is stretch, easy to clean
- Bowl is stretch: dedicated custom molds for bowl and drainage more easily
- Height adjustable 870-970mm

### 600 series

Model	Product Dim (W/D/H mm)	40 HQ Container loading
STK66BM1	600x600x870+100	418
STK86BM1	800x600x870+100	321

### 700 series

Model	Product Dim (W/D/H mm)	40 HQ Container loading
STK67BM1	600x700x870+100	362
STK87BM1	800x700x870+100	247

## DISHWASHER SINK - 1 BASIN ON THE LEFT/RIGHT



STK126SBL1



STK127SBR1



- High quality stainless steel
- Easy to assemble
- Top is stretch, easy to clean
- Bowl is stretch: dedicated custom molds for bowl and drainage more easily
- Grooved board

### 600 series

Model	Product Dim (W/D/H mm)	40 HQ Container loading
STK126SBL	1200x600x870+100	219
<sup>1</sup> STK146SBL1	1400x600x870+100	189
STK126SBR	1200x600x870+100	219
<sup>1</sup> STK146SBR1	1400x600x870+100	189

### 700 series

Model	Product Dim (W/D/H mm)	40 HQ Container loading
STK127SBL	1200x700x870+100	190
<sup>1</sup> STK147SBL1	1400x700x870+100	145
STK127SBR	1200x700x870+100	190
<sup>1</sup> STK147SBR1	1400x700x870+100	145

## DISHWASHER SINK - 2 BASINS ON THE LEFT/RIGHT



STK186SBL2



STK186SBR2

### 600 series

Model	Product Dim (W/D/H mm)	40 HQ Container loading
STK166SBL	1600x600x870+100	166
<sup>2</sup> STK186SBL2	1800x600x870+100	148
STK206SBL	2000x600x870+100	134
<sup>2</sup> STK166SBR2	1600x600x870+100	166
STK186SBR	1800x600x870+100	148
<sup>2</sup> STK206SBR2	2000x600x870+100	134

### 700 series

Model	Product Dim (W/D/H mm)	40 HQ Container loading
STK167SBL	1600x700x870+100	128
<sup>2</sup> STK187SBL2	1800x700x870+100	114
STK207SBL	2000x700x870+100	103
<sup>2</sup> STK167SBR2	1600x700x870+100	128
STK187SBR	1800x700x870+100	114
<sup>2</sup> STK207SBR2	2000x700x870+100	103

# STAINLESS STEEL

## HAND WASH SINK



HWR56K  
HWR57K

- High quality stainless steel
- Easy to assemble with over shelf
- Stretch bowl

Model	Product Dim(W/D/H mm)	40 HQ Container loading
HWR56	500x600x870+30	355
HWR57K	500x700x870+30	306

## STAINLESS STEEL SINK - 1 BOWL

- High quality stainless steel
- Wing door(s)
- Rounded edges
- Height adjustable feet



SSK66BM1



SSK86BM1

### 600 series

Model	Product Dim(W/D/H mm)	40 HQ Container loading
SSK66BM	600x600x870+100	156
<sup>1</sup> SSK86BM1	800x600x870+100	118

### 700 series

Model	Product Dim(W/D/H mm)	40 HQ Container loading
SSK67BM	600x700x870+100	134
<sup>1</sup> SSK87BM1	800x700x870+100	102

## STAINLESS STEEL SINK CABINET - 1 BASIN ON THE LEFT

- High quality stainless steel
- 2 sliding doors
- Easy to clean



SSK126BL1

### 600 series

Model	Product Dim(W/D/H mm)	40 HQ Container loading
SSK106BL	1000x600x870+100	104
<sup>1</sup> SSK126BL1	1200x600x870+100	87
SSK146BL <sup>1</sup>	1400x600x870+100	75

### 700 series

Model	Product Dim(W/D/H mm)	40 HQ Container loading
SSK107BL	1000x700x870+100	90
<sup>1</sup> SSK127BL1	1200x700x870+100	75
SSK147BL <sup>1</sup>	1400x700x870+100	65



# STAINLESS STEEL

## STAINLESS STEEL SINK CABINET



SSAAK126BL1S

### Bowl left side

Model	Product Dim (W/D/H mm)	40 HQ Container loading
SSAAK126BL1	1200x600x870+100	84
SSAAK127BL1S	1200x700x870+100	73



SSAAK126BR1S

### Bowl right side

Model	Product Dim (W/D/H mm)	40 HQ Container loading
SSAAK126BR1	1200x600x870+100	84
SSAAK127BR1S	1200x700x870+100	73

## STAINLESS STEEL SINK - 2 BASINS IN THE MIDDLE

- High quality stainless steel
- 2 sliding doors
- Back panel open



SSK206BM2  
SSK207BM2

Model	Product Dim(W/D/H mm)	40 HQ Container loading
SSK206BM	2000x600x870+100	53
2 SSK207BM2	2000x700x870+100	46

## DISHWASHER CABINET - 1 BASIN ON THE LEFT

- High-strength stainless steel
- The sink could be fitted with a connection to the dishwasher
- Hinged door(s)



SSK146SBL1

### 600 series

Model	Product Dim(W/D/H mm)	40 HQ Container loading
SSK126SBL	1200x600x870+100	87
1 SSK146SBL1	1400x600x870+100	75

### 700 series

Model	Product Dim(W/D/H mm)	40 HQ Container loading
SSK127SBL	1200x700x870+100	75
1 SSK147SBL1	1400x700x870+100	65

## DISHWASHER CABINET - 1 BASIN ON THE RIGHT



SSK126SBR1

### 600 series

Model	Product Dim(W/D/H mm)	40 HQ Container loading
SSK126SBR	1200x600x870+100	87
<sup>1</sup> SSK146SBR	1400x600x870+100	75



SSK146SBR1

### 700 series

Model	Product Dim(W/D/H mm)	40 HQ Container loading
SSK127SBR	1200x700x870+100	75
<sup>1</sup> SSK147SBR1	1400x700x870+100	65

## DISHWASHER CABINET - 2 BASINS LEFT



SSK166SBL2

### 600 series

Model	Product Dim(W/D/H mm)	40 HQ Container loading
SSK166SBL2	1600x600x870+100	66
SSK186SBL2	1800x600x870+100	59
<sup>2</sup> SSK206SBL	2000x600x870+100	53
<sup>2</sup> SSK207SBL2		

- High-strength stainless steel
- The sink cabinet could be fitted with a connection to the dishwasher
- 2 sliding doors

### 700 series

Model	Product Dim(W/D/H mm)	40 HQ Container loading
SSK167SBL	1600x700x870+100	57
<sup>2</sup> SSK187SBL2	1800x700x870+100	51
	2000x700x870+100	46

## DISHWASHER CABINET - 2 BASINS ON THE RIGHT



SSK186SBR2

### 600 series

Model	Product Dim(W/D/H mm)	40 HQ Container loading
SSK166SBR	1600x600x870+100	66
<sup>2</sup> SSK186SBR	1800x600x870+100	59
<sup>2</sup> SSK206SBR	2000x600x870+100	53
<sup>2</sup>		

### 700 series

Model	Product Dim(W/D/H mm)	40 HQ Container loading
SSK167SBR	1600x700x870+100	57
<sup>2</sup> SSK187SBR2	1800x700x870+100	51
SSK207SBR	2000x700x870+100	46
<sup>2</sup>		

# STAINLESS STEEL

## STAINLESS STEEL WORK CABINET - WITHOUT UPSTAND

- Worktop made of double-walled stainless steel
- Work surface without upstand
- Single hinged door or 2 sliding doors



ASK66



ASK126



ASK186

### 600 series

Model	Product Dim (W/D/H mm)	40 HQ Container loading
ASK6	600x600x870	192
ASK86	800x600x870	131
ASK10	1000x600x870	119
ASK126	1200x600x870	99
ASK14	1400x600x870	86
ASK166	1600x600x870	75
ASK18	1800x600x870	67
ASK206	2000x600x870	60

### 700 series

Model	Product Dim (W/D/H mm)	40 HQ Container loading
ASK6	600x700x870	167
ASK87	800x700x870	113
ASK10	1000x700x870	102
ASK127	1200x700x870	86
ASK14	1400x700x870	74
ASK167	1600x700x870	65
ASK18	1800x700x870	58
ASK207	2000x700x870	52

### 800 series

Model	Product Dim (W/D/H mm)	40 HQ Container loading
ASK10	1000x800x870	88
ASK128	1200x800x870	74
ASK14	1400x800x870	64
ASK168	1600x800x870	56
ASK18	1800x800x870	50
ASK208	2000x800x870	45

## STAINLESS STEEL WORK CABINET - WITH UPSTAND

- High quality stainless steel
- Height-adjustable shelf
- Single hinged door or 2 sliding doors



ASK66A



ASK126A



ASK166A

### 600 series

Model	Product Dim (W/D/H mm)	40 HQ Container loading
ASK66A	600x600x870+100	173
ASK86A	800x600x870+100	119
ASK106A	1000x600x870+100	107
ASK126A	1200x600x870+100	89
ASK146A	1400x600x870+100	77
ASK166A	1600x600x870+100	68
ASK186A	1800x600x870+100	60
ASK206A	2000x600x870+100	54

### 700 series

Model	Product Dim (W/D/H mm)	40 HQ Container loading
ASK67A	600x700x870+100	150
ASK87A	800x700x870+100	103
ASK107A	1000x700x870+100	92
ASK127A	1200x700x870+100	77
ASK147A	1400x700x870+100	67
ASK167A	1600x700x870+100	58
ASK187A	1800x700x870+100	52
ASK207A	2000x700x870+100	47

### 800 series

Model	Product Dim (W/D/H mm)	40 HQ Container loading
ASK108A	1000x800x870+100	80
ASK128A	1200x800x870+100	67
ASK148A	1400x800x85+100	57
ASK168A	1600x800x870+100	50
ASK188A	1800x800x870+100	44
ASK208A	2000x800x870+100	40

## STAINLESS STEEL WORK CABINET - WITH 3 DRAWERS ON THE RIGHT WITHOUT UPSTAND



ASK166R3

- Body, drawers and doors in high quality stainless steel
- Work surface without upstand
- 2 double-walled sliding doors

### 600 series

Model	Product Dim (W/D/H mm)	40 HQ Container loading
ASK146R	1400x600x870	86
ASK166R3	1600x600x870	75
ASK186R	1800x600x870	67
ASK206R3	2000x600x870	60

### 700 series

Model	Product Dim (W/D/H mm)	40 HQ Container loading
ASK147R	1400x700x870	74
ASK167R3	1600x700x870	65
ASK187R	1800x700x870	58
ASK207R3	2000x700x870	52

## STAINLESS STEEL WORK CABINET - WITH 3 DRAWERS ON THE RIGHT & UPSTAND



ASK166R3A

- Body, drawers and doors in high quality stainless steel
- Work surface with upstand
- 2 double-walled sliding doors
- Height-adjustable shelf

### 600 series

Model	Product Dim (W/D/H mm)	40 HQ Container loading
ASK146R3	1400x600x870+100	77
A ASK166R3A	1600x600x870+100	68
ASK186R3	1800x600x870+100	60
A ASK206R3A	2000x600x870+100	54

### 700 series

Model	Product Dim (W/D/H mm)	40 HQ Container loading
ASK147R3	1400x700x870+100	67
A ASK167R3A	1600x700x870+100	58
ASK187R3	1800x700x870+100	52
A ASK207R3A	2000x700x870+100	47

## STAINLESS STEEL WORK CABINET - WITH 3 DRAWERS ON THE LEFT WITHOUT UPSTAND



ASK166L3

- Body, drawers and doors in high quality stainless steel
- Work surface without upstand
- 2 double-walled sliding doors

### 600 series

Model	Product Dim(W/D/H mm)	40 HQ Container loading
ASK146L3	1400x600x870	86
ASK166L3	1600x600x870	75
ASK186L	1800x600x870	67
3 ASK206L3	2000x600x870	60

### 700 series

Model	Product Dim(W/D/H mm)	40 HQ Container loading
ASK147L	1400x700x870	74
3 ASK167L3	1600x700x870	65
ASK187L	1800x700x870	58
3 ASK207L3	2000x700x870	52

# STAINLESS STEEL

## STAINLESS STEEL WORK CABINET - WITH 3 DRAWERS ON THE LEFT

### ON STAND



ASK166L3A

- High quality stainless steel
- Middle shelf height can be adjustable
- The door is double-layered and more stable
- The door pulley sounds small and quiet.
- The door is easy to disassemble
- Height adjustable 870-970mm
- Two choices with and without splash back: with the splash back to prevent water from splashing onto the wall, without the splash back can be spliced together
- Silent pulley for drawers
- Different drawers that can be stored separately

### 600 series

Model	Product Dim (W/D/H mm)	40 HQ Container loading
ASK146L3	1400x600x870+100	77
ASK166L3A	1600x600x870+100	68
ASK186L3	1800x600x870+100	60
ASK206L3A	2000x600x870+100	54

### 700 series

Model	Product Dim (W/D/H mm)	40 HQ Container loading
ASK147L3	1400x700x870+100	67
ASK167L3A	1600x700x870+100	58
ASK187L3	1800x700x870+100	52
ASK207L3A	2000x700x870+100	47

## STAINLESS STEEL WORK CABINET WITH HATCH



ADK126



ADK166

- There are doors on both sides, and both sides can be opened. Convenient for both sides to operate at the same time.
- Save work time and improve work efficiency.
- Can be placed in the center of the kitchen to save operating space
- Large capacity storage space
- High quality stainless steel
- Middle shelf height can be adjustable
- The door is double-layered and more stable
- The door sounds small and quiet.
- The door is easy to disassemble



ADK206

### 600 series

Model	Product Dim (W/D/H mm)	40 HQ Container loading
ADK10	1000x600x870	119
6 ADK126	1200x600x870	99
ADK14	1400x600x870	86
6 ADK166	1600x600x870	75
ADK18	1800x600x870	67
6 ADK206	2000x600x870	60

### 700 series

Model	Product Dim (W/D/H mm)	40 HQ Container loading
ADK10	1000x700x870	102
7 ADK127	1200x700x870	86
ADK14	1400x700x870	74
7 ADK167	1600x700x870	65
ADK18	1800x700x870	58
7 ADK207	2000x700x870	52

## BEVERAGE DISPENSER BASE CABINET WITH CUP HOLDERS & ICE TRAY

- Made entirely of high quality stainless steel
- High functionality and stable quality
- Modern Design
- 3/4 cup dispensers
- 1 ice cube compartment
- Uncooled ice cube compartment with integrated water drain



KBASK120



KBASK150

Model	Product Dim(W/D/H mm)	40 HQ Container loading
KBASK12	1200x800x800	46
KBASK150	1500x800x800	28

## SUBSTRUCTURE

- Body made of high quality stainless steel
- Black oxidized stainless steel doors
- The highest standard in processing
- Color of the doors: high-gloss black



GK466T



GK866T



GK126T



GK166T

Model	Product Dim(W/D/H mm)	40 HQ Container loading
GK466 T	400x660x587	390
GK866T	800x660x587	210
GK126 T	1200x660x587	130
GK166T	1600x660x587	120

- Body and doors in high quality stainless steel
- Can be combined with other products in the series: Mario 700
- Easy to clean



UBK400-E  
UBK46-E



UBK800-E  
UBK66-E



UBK1200-E  
UBK126-E



UBK1600-E  
UBK166-E

## 560 series

Model	Product Dim (W/D/H mm)	40 HQ Container loading
UBK46-E	400x560x587	475
UBK66-E	800x560x587	266
UBK126-E	1200x560x587	140
UBK166-E	1600x560x587	135

## 660 series

Model	Product Dim (W/D/H mm)	40 HQ Container loading
UBK400-E UBK800-E	400x660x587	390
UBK1200-E	800x660x587	210
UBK1600-E	1200x660x587	130
UBK1600-E	1600x660x587	120

# STAINLESS STEEL

## RUBBISH BIN WITH ROLL CONTAINER

- Rubbish bin (square) with roll container
- Rubbish collecting table with hole dia.210mm
- Insertion opening & front pull-out
- Removable waste bin



MEK77LN



MEK77ALN

Model	Product Dim(W/D/H mm)	40 HQ Container loading
MEK77L	700x700x870	142
MEK77ALN	700x700x870+100	128

- High quality stainless steel
- Rubbish collecting table without hole
- Removable



MEK77 N



MEK77AN

Model	Product Dim(W/D/H mm)	40 HQ Container loading
MEK77	700x700x800	142
N MEK77AN	700x700x800+100	128

## FLOUR TROLLEY

- High quality stainless steel
- With two-part lid
- Splashproof



AEK46  
AEK47

Model	Product Dim(W/D/H mm)	40 HQ Container loading
AEK4	400x600x790	332
6 AEK47	400x700x790	286

## LITTER BIN WITH LIFT LID



ABFK100

- Trash can (round)
- High quality stainless steel
- Capacity : 100 liters
- With foot pedal
- Automatically lifting hinged lid



ABFK100D

- Trash can (round)
- High quality stainless steel
- Capacity : 100 liters
- Wheels & Handles
- With lifting lid

Model	Product Dim (W/D/H mm)	40 HQ Container loading
ABFK10	φ=450 460x610x720	180
ABFK50	φ=380 365x540x630	204
ABFK75	φ=450 460x610x610	192

Model	Product Dim (W/D/H mm)	40 HQ Container loading
ABFK100	φ=450 460x610x720	180
ABFK50D	φ=380 395x540x630	204
ABFK75D	φ=450 465x610x630	192

## DRAWER CABINET



SS2K56  
SS2K57



SS2K56A  
SS2K57A



SS3K56  
SS3K57



SS3K56A  
SS3K57A

- Body and drawers in high quality stainless steel
- Rounded edges
- Height-adjustable stainless steel feet
- Fits in the drawers: 1/2, 1/4, 2/8, 1/3, 1/6, 1/9 GN containers



SS4K56  
SS4K57



4K56  
4K57



SS6K106  
SS6K107



SS6K106A  
SS6K107A

### 600 series

Model	Product Dim	40 HQ Container loading
SS2K56 SS2K56A	500x600x870 500x600x870+100	228 205
SS3K56 SS3K56A	500x600x870 500x600x870+100	228 205
SS4K56 SS4K56A	500x600x870 500x600x870+100	228 205
SS6K106	1000x600x870	119
SS6K106A	1000x600x870+100	107

### 700 series

Model	Product Dim (W/D/H mm)	40 HQ Container
SS2K57 SS2K57A	500x700x870 500x700x870+100	197 178
SS3K57 SS3K57A	500x700x870 500x700x870+100	197 178
SS4K57 SS4K57A	500x700x870 500x700x870+100	197 178
SS6K107	1000x600x870	100
SS6K107A	1000x600x870+100	92

# STAINLESS STEEL

## CORNER CABINET

- High quality stainless steel
- Work surface with upstand or without upstand
- 1 hinged door
- Space saving



ESK106  
ESK107



ESK106A  
ESK107A

### 600 series

Model	Product Dim (W/D/H mm)	40 HQ Container loading
ESK10	1000x600x870	73
ESK106A	1000x600x870+100	66

### 700 series

Model	Product Dim (W/D/H mm)	40 HQ Container loading
ESK10	1000x700x870	73
ESK107A	1000x700x870+100	66

## CORNER WORK TABLE



ATEK108



ATEK108A

Model	Product Dim(W/D/H mm)	40 HQ Container loading
ATEK10	1000x600+600x1000x870	260
ATEK107	1000x700+700x1000x870	260
ATEK10	1150x800+800x1150x870	210

Model	Product Dim(W/D/H mm)	40 HQ Container loading
ATEK106	1000x600+600x1000x870+100	200
ATEK107A	1000x700+700x1000x870+100	200
ATEK108	1150x800+800x1150x870+100	180

## TABLEWARE CABINET

- High quality stainless steel
- Middle shelf height can be adjustable
- The door is double-layered and more stable
- The door pulley sounds small and quiet
- The door is easy to disassemble
- Height adjustable



GSK660



GSK1060



GSK1460

### 600 series

Model	Product Dim (W/D/H mm)	40 HQ Container loading
GSK660	600x600x1800	98
GSK860	800x600x1800	75
GSK1060	1000x600x1800	60
GSK1260	1200x600x1800	50
GSK1460	1400x600x1800	43
GSK1660	1600x600x1800	38

### 700 series

Model	Product Dim (W/D/H mm)	40 HQ Container loading
GSK670	600x700x1800	85
GSK870	800x700x1800	64
GSK1070	1000x700x1800	52
GSK1270	1200x700x1800	43
GSK1470	1400x700x1800	37
GSK1670	1600x700x1800	33

## WALL CABINET

- High quality stainless steel
- Middle shelf height can be adjustable
- Easy to install



WOK104



WOK208



WOK810

### 650 series

Model	Product Dim (W/D/H mm)	40 HQ Container loading
WOK8	800x400x650	292
WOK104	1000x400x650	236
WOK12	1200x400x650	197
WOK144	1400x400x650	170
WOK16	1600x400x650	149
4 WOK184	1800x400x650	133
WOK20	2000x400x650	120
4		

### 800 series

Model	Product Dim (W/D/H mm)	40 HQ Container loading
WOK8	800x400x800	240
WOK108	1000x400x800	193
WOK12	1200x400x800	162
WOK148	1400x400x800	139
WOK16	1600x400x800	122
8 WOK188	1800x400x800	109
WOK20	2000x400x800	98
8		

### 1000 series

Model	Product Dim (W/D/H mm)	40 HQ Container loading
WOK81	800x400x1000	193
WOK1010	1000x400x1000	156
WOK121	1200x400x1000	130
WOK1410	1400x400x1000	112
WOK161	1600x400x1000	98
0 WOK1810	1800x400x1000	88
WOK201	2000x400x1000	79
0		

- High quality stainless steel
- Middle shelf height can be adjustable
- The door is double-layered and more stable
- The door sounds small and quiet.
- The door is easy to disassemble
- Easy to install



WSK64



WSK84



WSK124

### 650 series

Model	Product Dim(W/D/H mm)	40 HQ Container loading
WSK6	600x400x650	386
4 WSK84	800x400x650	292
WSK10	1000x400x650	236
4 WSK124	1200x400x650	197
WSK14	1400x400x650	170
4 WSK164	1600x400x650	149
WSK18	1800x400x650	133
4 WSK204	2000x400x650	120

# STAINLESS STEEL

## WALL CABINET

- High quality stainless steel
- Very high load capacity Hinged or sliding doors available
- Intermediate floor



WSK88



WSK810



WSK1210

### 800 series

Model	Product Dim (W/D/H mm)	40 HQ Container loading
WSK8	800x400x800	240
WSK108	1000x400x800	193
WSK12	1200x400x800	162
WSK148	1400x400x800	139
WSK16	1600x400x800	122
WSK188	1800x400x800	109
WSK208	2000x400x800	98

### 1000 series

Model	Product Dim (W/D/H mm)	40 HQ Container loading
WSK81	800x400x1000	193
WSK1010	1000x400x1000	156
WSK121	1200x400x1000	130
WSK1410	1400x400x1000	112
WSK161	1600x400x1000	98
WSK1810	1800x400x1000	88
WSK2010	2000x400x1000	79

## SELF ASSEMBLY



without sliding door

WOK104Z

- Additional storage space for prep materials
- Open design
- Rounded corners
- Extremely high carrying capacity
- space-saving
- Compact, robust design
- Ground and middle shelf
- High-quality stainless steel



Sliding door enables gently opening and closing

Model	Product Dim (W/D/H mm)	40 HQ Container loading
WOK84Z	800x400x650	475
WOK104Z	1000x400x650	410
WOK124Z	1200x400x650	320
WOK144Z	1400x400x650	310
WOK164Z	1600x400x650	270
WOK184Z	1800x400x650	240
WOK204Z	2000x400x650	220

Model	Product Dim (W/D/H mm)	40 HQ Container loading
WSK64Z	600x400x650	620
WSK84Z	800x400x650	455
WSK104Z	1000x400x650	380
WSK124Z	1200x400x650	335
WSK144Z	1400x400x650	300
WSK164Z	1600x400x650	265
WSK184Z	1800x400x650	235
WSK204Z	2000x400x650	210

## SELF ASSEMBLY



ASFK106

- Rounded corners
- Ideal working height
- Extremely high carrying capacity
- Ground and middle shelf
- Doors with soft open/close mechanism
- Body and doors made of premium stainless steel
- Easy to clean
- Easy mounting

### 600 series

Model	Product Dim (W/D/H mm)	40 HQ Container loading
ASFK10	1000x600x870	287
ASFK126	1200x600x870	244
ASFK14	1400x600x870	213
ASFK166	1600x600x870	188
ASFK18	1800x600x870	169
ASFK206	2000x600x870	153

### 700 series

Model	Product Dim (W/D/H mm)	40 HQ Container loading
ASFK10	1000x700x870	243
ASFK127	1200x700x870	225
ASFK14	1400x700x870	196
ASFK167	1600x700x870	173
ASFK18	1800x700x870	155
ASFK207	2000x700x870	140



ASFK106A

- Rounded corners
- Ideal working height
- Extremely high carrying capacity
- Ground and middle shelf
- Doors with soft open/close mechanism
- Body and doors made of premium stainless steel
- Easy to clean
- Easy mounting

### 600 series

Model	Product Dim (W/D/H mm)	40 HQ Container loading
ASFK106	1000x600x870+100	243
A ASFK126A	1200x600x870+100	225
ASFK146	1400x600x870+100	196
A ASFK166A	1600x600x870+100	173
ASFK186	1800x600x870+100	155
A ASFK206A	2000x600x870+100	140

### 700 series

Model	Product Dim (W/D/H mm)	40 HQ Container loading
ASFK107	1000x700x870+100	228
A ASFK127A	1200x700x870+100	211
ASFK147	1400x700x870+100	183
A ASFK167A	1600x700x870+100	162
ASFK187	1800x700x870+100	145
A ASFK207A	2000x700x870+100	132

# STAINLESS STEEL

## STAINLESS STEEL CASH DESK



KTK57

- High quality stainless steel cash desk
- Suitable for pizzerias
- Additional storage space for work materials
- Height adjustable feet



KTK57S

### open door

Model	Product Dim (W/D/H mm)	40 HQ Container loading
KTK57	500x700x870+150	152
KTK58	500x800x870+150	134

### with drawer

Model	Product Dim (W/D/H mm)	40 HQ Container loading
KTK57	500x700x870+150	152
KTK58S	500x800x870+150	134

## WALL-HANGING CABINET WITH 1 LAYER MIDDLE SHELF AND DOORS

- High quality stainless steel
- Height adjustable



EHK165

Model	Product Dim(W/D/H mm)	40 HQ Container loading
EHK165	1000x400x650	92

## EXHAUST HOOD NO BLOWER WITH FILTER



WHK107



WHK127



WHK147

Model	Product Dim(W/D/H mm)	40 HQ Container loading
WHK107	1000x450x700	150
WHK127	1200x450x700	130
WHK147	1400x450x700	110

## FLAME PROTECTION FILTER

- High quality stainless steel
- Temperature resistant, long lifetime
- Reliable prevention of flame propagation
- Efficient removal of grease vapor
- Suitable for kitchen areas with food serving, food storage, scullery



FSK5050

Model	Product Dim(W/D/H mm)	40 HQ Container loading
FSK4040	400x400x20	8910
FSK5050	500x500x20	8910

## FOOD SHELF

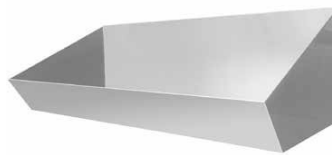

AUWK120

Model	Product Dim(W/D/H mm)	40 HQ Container loading
AUWK100	1000x385x260	572
AUWK80	800x385x260	678

## WALL SHELVES

- High quality stainless steel
- Easy to assemble
- Can be added layers to make more layers
- Height adjustable
- Strong bearing capacity



WBK183

### 300 series

Model	Product Dim (W/D/H mm)	40 HQ Container loading
WBK63	600x300x660	3227
WBK83	800x300x660	2448
WBK103	1000x300x660	1972
WBK123	1200x300x660	1651
WBK143	1400x300x660	1420
WBK153	1500x300x660	1315
WBK163	1600x300x660	1246
WBK183	1800x300x660	1109
WBK203	2000x300x660	1000

### 400 series

Model	Product Dim (W/D/H mm)	40 HQ Container loading
WBK64	600x400x660	2448
WBK84	800x400x660	1868
WBK104	1000x400x660	1511
WBK124	1200x400x660	1268
WBK144	1400x400x660	1076
WBK154	1500x400x660	1014
WBK164	1600x400x660	947
WBK184	1800x400x660	845
WBK204	2000x400x660	763

# STAINLESS STEEL

## STAINLESS STEEL SHELF - WITH 4 SHELVES(ADJUSTABLE)

- Completely made of high quality stainless steel
- Round stainless steel legs, screw connection guarantees high stability
- 4 smooth shelves, max. load per shelf: 80 kg
- Suitable for laboratories & clean rooms, storage rooms & dry storage, hospitals or for private use, cold rooms (up to -80 °C) and canteen kitchens etc.



Model	Product Dim (W/D/H mm)	40 HQ Container loading
ERP105	1000x500x1800	440
N ERP125	1200x500x1800	370
N ERP145	1400x500x1800	320
N ERP165	1600x500x1800	280
N ERP185	1800x500x1800	250
N ERP205	2000x500x1800	220

## SINGLE ADDITIONAL SHELF



Model	Product Dim(W/D mm)
ERP105-	1000x500
ERP125-1	1200x500
ERP145-	1400x500
ERP165-1	1600x500
ERP185-	1800x500
ERP205-1	2000x500

## SERVING TROLLEY

- High quality stainless steel
- Facilitates the transport of drinks, food and crockery
- Wheels can be locked for a secure stand
- Max. load: 40kg (per shelf)



### 500 series

Model	Product Dim (W/D/H mm)	40 HQ Container loading
S2K85	800x500x940	922
S2K105	1000x500x940	747
S3K85	800x500x940	703
S3K105	1000x500x940	573

### 600 series

Model	Product Dim (W/D/H mm)	40 HQ Container loading
S2K106	1000x600x940	640
S2K126	1200x600x940	534
S3K106	1000x600x940	486
S3K126	1200x600x940	408

## FOLDABLE SERVING TROLLEY

- Save the time and convenient to use, no need to assemble
- Save the space after used and folded
- Convenient to carry on the car for outdoors
- Durable design on the trolley: 50kgs/ layer max.loading capacity when transportation



SWH83

SWKH83

SWH63

Model	Product Dim(W/D/H mm)	40 HQ Container loading
SWH83	880x500x930	320
SWKH8	930x510x930	260
3 SWH63	635x402x910	412

## PLASTIC SERVING TROLLEY

- Good quality of PP material with strong toughness, not easy to damage even if it is stepped on or thrown at high altitude
- Matte surface, wear-resistant and non-slip



SWKH11



SWKH12

Model	Product Dim(W/D/H mm)	40 HQ Container loading
SWKH1	1020x490x980	540
3 SWKH12	1020x490x980	840

## TROLLEY WITH UNDER SHELF

- Serving trolley with 2 shelves
- High quality stainless steel
- For 2 x 12 x GN 1/6 containers
- 4 castors, 2 of which have brakes



SWH16

Model	Product Dim(W/D/H mm)	40 HQ Container loading
SWH16	798x520x940	920

## 5 SHELVES SERVING TROLLEY

- Less transportation noise
- Good loading capacity
- More display space for 5 layer trolley, sometime can work as a storage rack when lock the wheel



SWH85N

Model	Product Dim(W/D/H mm)	40 HQ Container loading
SWH85N	845x525x1550	570

# STAINLESS STEEL

## CLEANING TROLLEY

- With 3 shelves & 2 buckets
- Facilitates the transport of detergents, rubbish, etc.
- 4 wheels with parking brake, can be locked for a secure stand



GRWH5#AERWH5

Model	Product Dim(W/D/H mm)	40 HQ Container loading
GRWH	850×455×935	660
5 AERWH5	535×380×150 /280x200x300	1080

## TRANSPORT TROLLEY

- Convenient to use in foldable design and no need to assemble
- Facilitates the transport of drinks, food and crockery
- Low platform trolley, 1 shelf
- Easy rolling, with 2 fixed and 2 swivel castors



TWH81

Model	Product Dim(W/D/H mm)	40 HQ Container loading
TWH81	820x515x935	800

- Convenient to use in foldable design and no need to assemble
- Max. loading capacity: 150kgs
- With 4 pcs of anti-slip rubber particles on the top



TWH71

Model	Product Dim(W/D/H mm)	40 HQ Container loading
TWH71	730 x 480 x 820	1000

## INGREDIENT TROLLEY

- High quality stainless steel
- With two-part lid
- With wheels for high mobility



MWH50

Model	Product Dim(W/D/H mm)	40 HQ Container loading
MWH50	590x670x575	240

## LAUNDRY TROLLEY

- Ideal for transporting laundry and textiles
- Equipped with 4 wheels
- Laundry bag made of high quality fabric
- Easy to use



WWH9

Model	Product Dim(W/D/H mm)	40 HQ Container loading
WWH9	910×560×920	580

## TRAY TROLLEY

- Double tray trolley
- Made of high quality stainless steel
- Perfect for restaurants and hotels
- For 16x GN 1/1
- 4 wheels with 2 brakes
- Easy to use
- Easy to clean
- low noise
- High stability
- Very resistant and durable
- Flexible



TWDH1611

- For 6x GN 1/1
- 4 wheels with 2 brakes
- High stability



TWH611

Model	Product Dim(W/D/H mm)	40 HQ Container loading
TWDH1611	740x550x1700	450
TWH611	380x550x950	1000



- Square legs for added strength
- Supplied flat packed with easy assembly
- Back support to stop tray sliding all the way through
- Suitable for 1/1, 1/2, 1/3 and 2/3 GN pans

TWH1611N



- Made from stainless steel
- Space for up to 16 trays
- Ideal for use in bakeries, restaurants, hotels and self-service outlets
- Suitable for GN 2/1, 1/1 trays

TWH1621N



- Quick and easy to assemble
- Equipped with casters, of which two have brakes
- Suitable for use with 60x40cm bakery pan

TWH1564N



- Made from stainless steel and very easy to assemble.
- 16 shelves available
- Suitable for Bakerynorm trays of 60 x 40cm and 1/1, 1/2, 1/3 and 2/3 GN pans

TWH1811N

Model	Product Dim(W/D/H mm)	40 HQ Container loading
TWH1611N	380x550x1700	627
TWH1621N	590x670x1700	554
TWH1564N	470x620x1700	484
TWH1811N	470x620x1735	421

- Tray trolley closed
- Perfect for restaurants and hotels
- 4Castors with 2 brakes
- Easy to operate
- Easy to clean
- Made of high quality stainless steel
- Extremely quiet
- High stability
- Very resistant and durable



TWK1411



TWK1464

Model	Product Dim(W/D/H mm)	40 HQ Container loading
TWK1411	460x640x1800	280
TWK1464	460x640x1800	280

# STAINLESS STEEL

## STAINLESS STEEL DISH RACK TROLLEY

- High quality stainless steel dish rack trolley for 4/6/7 baskets
- For baskets measuring: 40x40, 40x50 & 50x50 cm, as per different trolleys
- Easy rolling, 2 fixed and 2 swivel castors
- No sharp edges



Model	Product Dim(W/D/H mm)	40 HQ Container loading
GKWH45	505x550x1000	1000
GKWH44	455x400x1000	1000
GKWH75	505x550x1710	600
GKWH74	455x400x1710	696
GKWH65	505x550x1700	600

## PLATE STACKER

- Double plate stacker, made of high quality stainless steel
- Perfect for eg restaurants and hotels
- For up to 80 plates - Ø 23 - 30cm
- Very resistant and durable



Model	Product Dim(W/D/H mm)	40 HQ Container loading
TSDH80	606x598x1635	382

## STAINLESS STEEL FOLDABLE WORK TABLE

- Body made of high quality stainless steel
  - Save the time and convenient to use in foldable design and no need to install
  - On the top board with wooden board inside, which makes the table much stronger
- Work surface without upstand, square profile table legs



Model	Product Dim(W/D/H mm)	40 HQ Container loading
ATH106	1000x600x910	656
ATH126	1200x600x910	600
ATH146	1400x600x910	475
ATH166	1600x600x910	418
ATH186	1800x600x910	373
ATH206	2000x600x910	336

## BAGUETTE TRAY

- Made of high quality aluminum, with 5 holes
- Suitable for bakeries, easily removable
- Easy to clean



BABH46



BABH546

Model	Product Dim(W/D/H mm)	40 HQ Container loading
BABH4 6 BABH546	600x400x30	7200
	600x400x30	7200

## STAINLESS STEEL CUTLERY TRAY



BEBH13



BEBH14



BEBH15



BEBH24



BEBH36



BEBH36T

- Made of high-quality stainless steel
- Particularly suitable for canteens, snack bars, catering services and buffets
- Compact & space-saving, particularly hygienic, easy to clean

Model	Product Dim(W/D/H mm)	40 HQ Container loading
BEBH1 3 BEBH14	385x150x180	3960
	505x150x180	2640
BEBH1 5 BEBH24	630x150x180	2640
	265x305x200	2400
BEBH3 6 BEBH36T	385x305x200	1800
	385x305x200	1800

## WALL SHELF FOR DISHWASHING BASKETS

- High quality stainless steel
- Loading capacity: 50 kg
- Compact & robust design
- Easy to clean, temperature resistant
- Durable, space saving



WBSH55925

Model	Product Dim(W/D/H mm)	40 HQ Container loading
WBSH55925	559x457x286	5584
WBSH10625	1067x457x286	3066
WBSH15725	1575x457x286	2107
WBSH15025	1505x457x286	2201
WBSH20025	2005x457x286	1667
WBSH25025	2505x457x286	1341

Model	Product Dim(W/D/H mm)	40 HQ Container loading
WBSH55932	559x457x286	5584
WBSH15732	1575x457x286	2107
WBSH20032	2005x457x286	1667

# STAINLESS STEEL

## SPICE SHELF



GAH316



GAH416



GAH516



GAH616

Model	Product Dim(W/D/H mm)	40 HQ Container loading
GAH316	515×250×210	1600
GAH416	690×250×210	1320
GAH516	825×250×210	1060
GAH616	990×250×210	800

- High quality stainless steel
- Welding style, much stronger
- Easy to operate
- Easy to clean



GABK100



GABK120



GABK160



GABK180

Model	Product Dim(W/D/H mm)	40 HQ Container loading
GABK100	1000x310x220	490
GABK120	1200x310x220	413
GABK160	1600x310x220	313
GABK180	1800x310x220	280

- High quality stainless steel
- Welding style, much stronger
- With cover, is cleaner



GAK414



GAK614



GAK814



GAK1014

Model	Product Dim(W/D/H mm)	40 HQ Container loading
GAK414	800x311x264	530
GAK614	1200x311x264	360
GAK814	1600x311x264	274
GAK1014	2000x311x264	253

## CUP DISPENSER



BESGH2



BESGH3



BESGH4

Model	Product Dim (W/D/H mm)	40 HQ Container loading
BESGH	280x150x680	1160
BESGH3	460x150x680	800
BESGH4	580x150x680	680

## BUILT-IN CUP DISPENSER



EBESH80



EBESH90



EBESH100

Model	Product Dim (W/D/H mm)	40 HQ Container loading
EBESH8	80x115x 640	3200
EBESH90	90x115x640	3200
EBESH100	100x115x 640	3200

## S/S PET GROOMING BATHTUB

- High quality stainless steel
- Professional stainless steel pet grooming tub for grooming your pet
- Eliminate unpleasant odors and dirt in your premises with our pet care tub
- The mobile shower head allows you to easily clean your pet
- Excellent sealing performance eliminates water leakage
- The non-slip grooved surface on the stairs helps your pet to get in or out safely
- Storage grid for care products
- Pilot holes for hot and cold water connection



HTPWEL

HTPW

HTPWEV

Model	Product Dim(W/D/H mm)	40 HQ Container loading
HTPWE	1240×556×1420	94
HTPW	850×480×1076	309
HTPWEV	870×490×1020	240

## COFFEE GROUNDS DRAWER

- High quality stainless steel
- Height adjustable feet
- Easy to clean



KSK1041



KSK541

Model	Product Dim(W/D/H mm)	40 HQ Container loading
KSK54	410x510x115	2367
KSK1041	820x510x115	1224

# STAINLESS STEEL

## INSECT KILLER



IVG40

- Special UV-A tube with spectrum at 365mm as the best luring efficiency to the flying insects.
- Average working life of the tube: 8000 hours
- Special treated Aluminium Alloy material for no scratch, oil proof
- ABS fire-resistant plastic material of the side board.
- With chain holder at the top cover for easy hanging.
- Full protected outer mesh for high safety using.
- Removable collection tray for easy cleaning.
- Non-toxic, no spray, eco-friendly, and easy to use.
- Ideal for using at commercial areas, such as restaurants, canteens, offices, supermarkets, etc.

Model	Product Dim(W/D/H mm)	40 HQ Container loading
IVG1	330x100x263	5862
6 IVG2	380x100x263	5100
0 IVG4	635x100x311	2693
0		

## STAINLESS STEEL GN CONTAINER



- High quality stainless steel
- Stable and scratch-resistant
- Easy to use
- Easy to clean



GDY11



GBY1140



GBY11150



GDY11L



GBY1140G



GBY11150G

### GN 1/1

Model	Product Dim W/D/H mm)	40 HQ Container loading
GDY1	530x325	970
1 GBY1120	530x325x20	5680
GBY114	530x325x40	3220
0 GBY1165	530x325x65	2160
GBY1110	530x325x100	1410
0 GBY11150	530x325x150	1120
GBY1120	530x325x200	1050
0		

### GN 1/1

Model	Product Dim (W/D/H mm)	40 HQ Container loading
GDY11	530x325	970
L GBY1120G	530x325x20	5680
GBY1140	530x325x40	3220
G GBY1165G	530x325x65	2160
GBY11100	530x325x100	1410
G GBY11150G	530x325x150	1120
GBY11200	530x325x200	1050
G		

## STAINLESS STEEL GN CONTAINER



GDY12

GBY1240

GBY12150



GDY12L

GBY1220G

GBY12100G

GTY1210

### GN 1/2

Model	Product Dim (W/D/H mm)	40 HQ Container loading
GDY1	325x265	2240
GBY1220	325x265x20	3666
GBY124	325x265x40	5300
GBY1265	325x265x65	3400
GBY1210	325x265x100	1930
GBY12150	325x265x150	1850
GBY1220	325x265x200	1550
GTY1210	325x265x10	1000

### GN 1/2

Model	Product Dim (W/D/H mm)	40 HQ Container loading
GDY12	325x265	2240
GBY1220G	325x265x20	3666
GBY12100	325x265x100	1930
GBY12200G	325x265x200	1550



GDY13

GBY1340

GBY13150



GDY13L

GBY13150G

### GN 1/3

Model	Product Dim (W/D/H mm)	40 HQ Container loading
GDY1	325x176	1560
GBY1320	325x176x20	3666
GBY134	325x176x40	7130
GBY1365	325x176x65	3800
GBY1310	325x176x100	2350
GBY13150	325x176x150	2120
GBY1320	325x176x200	1940

### GN 1/3

Model	Product Dim (W/D/H mm)	40 HQ Container loading
GDY13	325x176	1560
GBY13100G	325x176x100	2350
GBY13150	325x176x150	2120
GBY13200G	325x176x200	1940

# STAINLESS STEEL

## STAINLESS STEEL GN CONTAINER



GDY14



GBY1465



GBY1665



GBY16150



GBY14200



GDY14L



GDY16



GDY16L

### GN 1/4

Model	Product Dim (W/D/H mm)	40 HQ Container loading
GDY14	265x162	4090
GDY14L	265x162	4090
GBY1440	265x162x40	2400
GBY1465	265x162x65	4960
GBY14100	265x162x100	3110
GBY14150	265x162x150	2790
GBY14200	265x162x200	720

### GN 1/6

Model	Product Dim (W/D/H mm)	40 HQ Container loading
GDY16	176x162	1680
GBY1665	176x162x65	7400
GBY16100	176x162x100	4950
GBY16150	176x162x150	4020
GBY16200	176x162x200	3517
GDY16L	176x162	1680



GDY19



GBY19100



GDY19L



GBY2140



GBY21150



GBY21100G



GBY2120G

### GN 1/9

Model	Product Dim (W/D/H mm)	40 HQ Container loading
GDY19	176x108	8640
GBY1965	176x108x65	10280
GBY19100	176x108x100	6540
GDY19L	176x108	8640

### GN 2/1

Model	Product Dim (W/D/H mm)	40 HQ Container loading
GBY2140	650x530x40	1510
GBY2165	650x530x65	756
GBY21150	650x530x150	492
GBY21200	650x530x200	420
GBY2120G	650x530x20	1692
GBY21100G	650x530x100	612
GBY21150G	650x530x150	492

## STAINLESS STEEL GN CONTAINER



### GN 2/3

Model	Product Dim (W/D/H mm)	40 HQ Container loading
GDY2	353x325	1710
GBY2320	353x325x20	3142
GBY234	353x325x40	1953
GBY2365	353x325x65	1900
GBY2310	353x325x100	1420
GBY23150	353x325x150	1330
GBY2320	353x325x200	558
GDY23L	353x325	1710

### GN 2/4

Model	Product Dim (W/D/H mm)	40 HQ Container loading
GDY2	530x162	1638
GBY2440	530x162x40	2394
GBY246	530x162x65	1134
GBY24100	530x162x100	1008
GBY2415	530x162x150	882

## MILK JUG WITH LID

- Food grade stainless steel, anti-rust and anti-corrosion
- The lid with a rubber seal and a latch ensures a secure closure
- Practical carrying handles for easy transport
- Ideal for milk, food, etc. Suitable for transport and storage
- Stable construction
- Widely used in various applications: using in farms, pastures, dairy plants, etc
- Easy to clean up: Clean with detergent and wipe dry



MKX25  
MKX40

Model	Product Dim (W/D/H mm)	Net Volume(L)	40 HQ Container loading
MKX25	320x200x420	25	1295
MKX40	380x250x470	40	804

# STAINLESS STEEL

## ALUMINUM PIZZA PEEL

- For pizza ovens
- Made of high quality aluminum
- Shovel for placing and removing pizzas from the pizza oven
- Extra light quality for better handling
- Heat resistance
- Easy handling
- Easy to clean



PSAJ28



PSAJ2317



PSAJ301



PSAJ3590



PSAJ337



PSAJ215



PSAJ3317

Model	Product Dim(W/D/H mm)	40 HQ Container loading
PSAJ2	228x228x800	2625
8 PSAJ2317	230x230x1700	1750
PSAJ30	300x300x1100	1750
1 PSAJ3590	305x355x905	1875
PSAJ33	310x350x660	1800
7 PSAJ215	170x240x510	3500
PSAJ331	405x455x1730	1296
7		

# SINK TAP

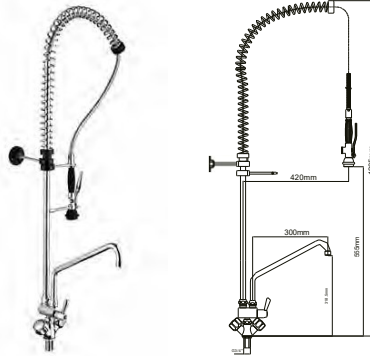

- One-hole dish spray
- 2 mixing valves
- With swivel spout
- Shower can be swiveled by 360°
- Stable and flexible spring

GY2

Model	Product Dim(W/D/H mm)	40 HQ Container loading
GY 2	21 x 430 x 1205	3500

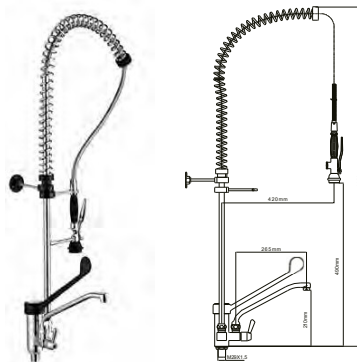

- One-hole dish spray
- Swivel tap & single lever mixer
- For wall mounting
- Shower can be swiveled by 360°

GY3

Model	Product Dim(W/D/H mm)	40 HQ Container loading
GY 3	21 x 420 x 1150	1400

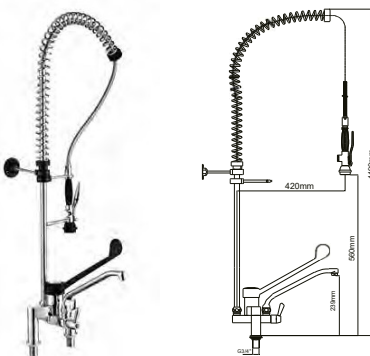

- Two-hole dish shower
- Swivel tap & single lever mixer
- For wall mounting
- Shower can be swiveled by 360°
- Very resistant and durable

GY4

Model	Product Dim(W/D/H mm)	40 HQ Container loading
GY 4	21 x 420 x 1190	1400

# STAINLESS STEEL

## SINK TAP

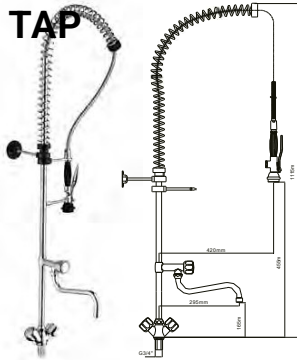

- One-hole dish spray
- 2 mixing valves
- With swivel spout on the standpipe
- Shower can be swiveled by 360°

GY6

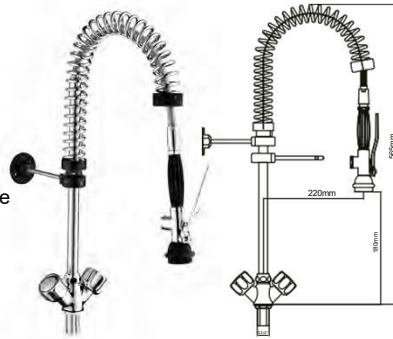

- One-hole dish spray
- Shower can be swiveled by 360°
- For wall mounting
- 2 mixing valves

GY7

Model	Product Dim(W/D/H mm)	40 HQ Container loading
GY6	21 x 420 x 1115	1750
GY7	21 x 220 x 565	1750

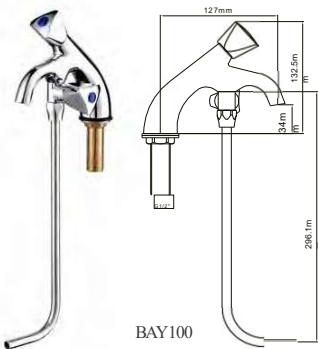

BAY100

- Single hole mixer tap
- Device for table mounting
- One-hole battery with 1 flushing pipe
- Suitable for: 1 sink

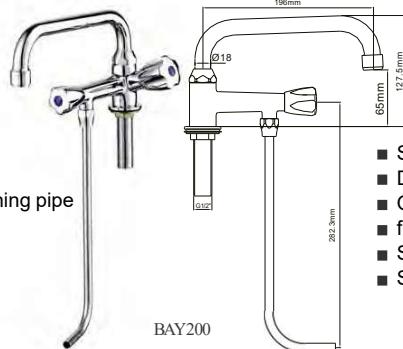

BAY200

- Single hole mixer tap
- Device for table mounting
- One-hole battery with 1 flushing pipe
- Swivel tap 360°
- Suitable for: 1 sink

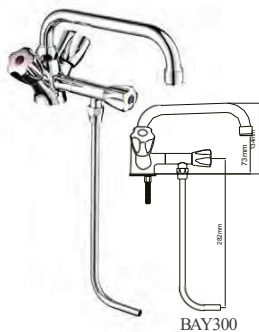

BAY300

- Single hole mixer tap
- Device for table mounting
- Swivel tap 360°
- Suitable for: 1 sink
- Easy to clean

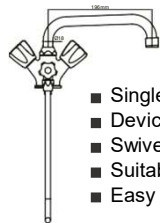

BAY400

- Single hole mixer tap
- Device for table mounting
- Swivel tap 360°
- Suitable for: 2 sinks

Model	Product Dim(W/D/H mm)	40 HQ Container loading
BAY100	34 x 127 x 460	6656
BAY200	65 x 196 x 460	6656
BAY300	73 x 196 x 460	6656
BAY400	73 x 196 x 460	6656

# SINK TAP

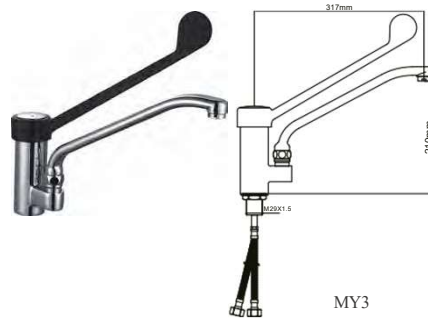

- Single hole mixer tap
- Swivel tap & single lever mixer
- Extra long faucet
- Solid plastic head and lever

Model	Product Dim(W/D/H mm)	40 HQ Container loading
MY3	307 x 50 x 250	6656

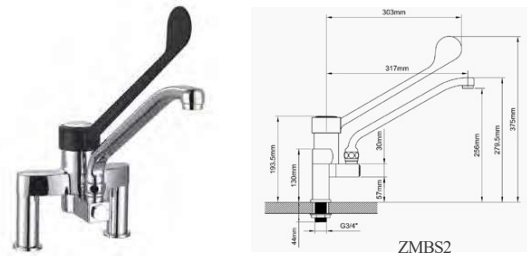

- Two hole mixer tap
- Extra long water tap
- Swivelling tap and single lever mixer
- Quick fitting
- Elegant and robust
- Finished with chromed metal
- Superior stability

Model	Product Dim(W/D/H mm)	40 HQ Container loading
ZMBS2	510x200x120	6656



- Single-hole mixer tap
- With swivel tap and single lever mixer
- Extra long water tap
- Quick fitting
- Easy mounting
- Finished with chromed metal
- Highly robust



- Single-hole mixer tap
- With swivel tap and single lever mixer
- Single lever mixer
- Flexible shower
- Easy mounting
- Finished with chromed metal
- Highly robust

Model	Product Dim(W/D/H mm)	40 HQ Container loading
EMBS6	345x165x70	11880
EMBS7	335x220x70	4320



- Inlet glass shower
- with grid cover
- with integrated water jet regulator
- Included: water stop automatic
- Robust and scratch-resistant
- Robust, functional & elegant



- Built-in soap dispenser
- Easy to clean
- Easy to fill
- Made of stainless steel

Model	Product Dim(W/D/H mm)	40 HQ Container loading
EGDB6	360x220x100	10368
ESPS10	320x220x95	5544
ESPS40	285x135x56	13860